

FAC

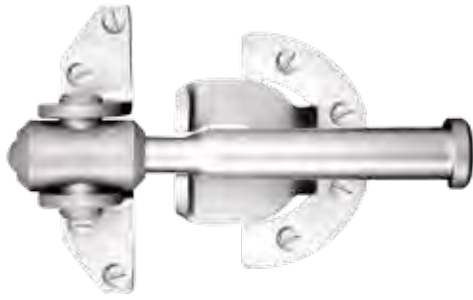

Innovador sistema anti-impacto
Fabricado en acero 100% tallado
en torno CNC y cortado en laser
Muelle interno destinado a absorber
la energía del impacto
Acabados: cromo brillo, cromo
satinado y dorado
Sólo disponible en blister

An innovating anti-impact system
Made in 100% steel worked in lathe
CNC and laser cutting
Internal spring to absorb the impact energy
Finish: polished chrome, satin
chrome and golden finish
Only available in blister

Um inovador sistema anti-impacto
Fabricado em aço 100% modelado
em torno CNC e cortado com laser
Mola interna destinada a absorver a
energia do impacto
Acabamentos em cromo brilhante,
cromo acetinado e dourado
Em Blister

ANTI-IMPACTO RETENEDOR

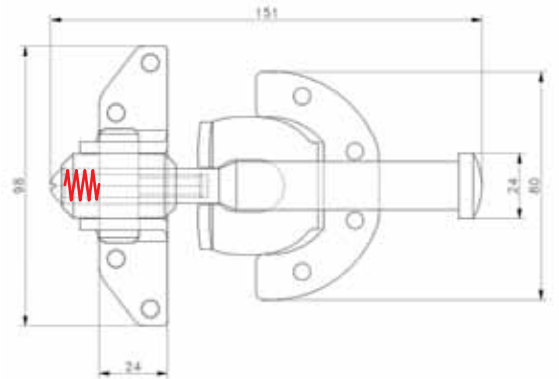

retenedor		
	Ref.	Embalaje
Cr. Satinado	03355	6
Dorado	03356	6
Cromado	03357	6

FAC



Acabado niquelado y dorado
Placa en chapa de acero de 2 mm
Cadena soldada con eslabón de
Ø 3 mm

Nickel plated and golden finish
2 mm steel plate
Ø 3 mm welded chain retainer

Acabamento niquelado e dourado
Placa em aço de 2 mm
Corrente de segurança com anéis
de 3 mm



600 RETENEDOR

retenedor		
	Ref.	Embalaje
Dorado	03352	12
Niquelado	03351	12

FAC

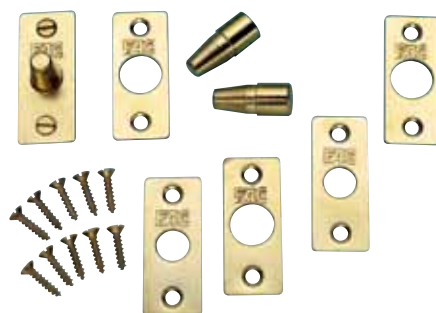

Pivotes de acero de 13 mm
Placa de acero de 2,1 mm
Placa de acabado latonado

13 mm steel bolts
2.1 mm steel plate
Brass plated finish

Trincos em aço de 13 mm
Placa em aço de 2,1 mm
Placa em acabamento latão

Refuerzo zona de bisagra

700 PIVOTES

pivotes para bisagra		
	Ref.	Embalaje
Juego de 3		
Dorado	08551	12