

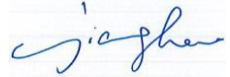



<p>TEST REPORT</p> <p>IEC 60884-1</p> <p>Plugs and socket-outlets for household and similar purposes</p> <p>Part 1: General requirements</p>	
Report Number.....	3190585.50v1.1
Date of issue	2016-06-27
Total number of pages	58 pages
Applicant's name	Allocacoc B.V.
Address	Rotterdamseweg 386 B1, 2629HG Delft, the Netherlands
Test specification:	
Standard.....	IEC 60884-1:2002 (Third Edition) + A1:2006 + A2:2013
Test procedure.....	type test
Non-standard test method	N/A
Test Report Form No.	IEC60884_1D (modified by DEKRA)
Test Report Form(s) Originator ...	IMQ S.p.A.
Master TRF.....	Dated 2013-08
Test item description.....	Multiple portable socket-outlets
Trade Mark	Allocacoc
Manufacturer	Suzhou Bortly Hardware Illumination Electric Appliance Co., Ltd. Fenyue Road, Fenu Economy & Technology Development Zone, Wujiang City, Jiangsu, China
Model/Type reference	1100/DEORPC, 1202/DEOUPC, 1103/DEORPC, 1203/DEOUPC
Ratings	250 V~; 16 A USB: 5 Vdc; 2,1 A

Testing procedure and testing location:		
<input checked="" type="checkbox"/>	Testing Laboratory:	DEKRA Testing and Certification (Shanghai) Ltd.
Testing location/ address :		3F #250 Jiangchangs Road Building 16 Headquarter Economy Park Shibe Hi-Tech Park, Zhabei District Shanghai 200436 CHINA
<input type="checkbox"/>	Associated CB Testing Laboratory:	
Testing location/ address :		
Tested by (name + signature).....:		Hao Jiang 
Approved by (name + signature).....:		Wenchao Ni 
<input type="checkbox"/>	Testing procedure: TMP	
Testing location/ address :		
Tested by (name + signature).....:		
Approved by (name + signature).....:		
<input type="checkbox"/>	Testing procedure: WMT	
Testing location/ address :		
Tested by (name + signature).....:		
Witnessed by (name + signature).....:		
Approved by (name + signature).....:		
<input type="checkbox"/>	Testing procedure: SMT	
Testing location/ address :		
Tested by (name + signature).....:		
Approved by (name + signature).....:		
Supervised by (name + signature) ..:		

<p>List of Attachments (including a total number of pages in each attachment):</p> <p>deviation of the Netherlands (4 pages)</p> <p>standard dimension sheet (3 page)</p> <p>pictures of product (11 pages)</p>	
<p>Summary of testing:</p>	
<p>Tests performed (name of test and test clause):</p> <p>Full type testing.</p>	<p>Testing location:</p> <p>DEKRA Testing and Certification (Shanghai) Ltd. 3F #250 Jiangchangsang Road Building 16 Headquarter Economy Park Shibe Hi-Tech Park, Zhabei District Shanghai 200436 CHINA</p>
<p>Summary of compliance with National Differences</p> <p>N/A</p>	
<p>Copy of marking plate</p> <div style="text-align: center;"> <p>PowerCube by allocacoc </p> <p>reddot award Honoured: name1 last1 name2 last2</p> <p>CE</p> <p>designed in the netherlands assembled in china</p> <p>MAX 16A/250V~ 3680W/50-60Hz</p> <p>1100/DEORPC NO.00000000 BN Code</p> <p>protected intellectual property</p> </div>	

Test item particulars	: multiple socket-outlets
Standard Sheet	: see Annexs plug and socket-outlet datasheet on page 45 to 47
Rated current (A) / Rated voltage (V)	: 16 / 250
Degree of protection against access to hazardous parts and against harmful ingress of solid foreign objects	: IP2X / IP4X / IP5X
Degree of protection against harmful ingress of water	: IPX0 / IPX4 / IPX5 / IPX6
Provision for earthing	: without earthing contact / with earthing contact
Method of connecting the cable	: rewirable / non-rewirable
Type of cable	: -
Nominal cross-sectional areas (mm²)	: -
Type of terminals	: screw-type / screwless (rigid) / screwless (rigid and flexible)
Type of connections	: soldered / welded / crimped / other
Socket-outlets:	
Degree of protection against electric shock	: normal protection / increased protection
Existence of shutters	: without shutters / with shutters
Method of application / mounting of the socket-outlet	: surface-type / flush-type / semi-flush-type / panel type / architrave-type / portable type / table-type (single/multiple) / floor recessed type / appliance type
Method of installation	: design A / design B
Intended for circuits where	: a single earthing circuit provides protective earthing / electrical noise immunity is desired for the earthing circuit
Plugs:	
Class of equipment	: 0 / I / II
Possible test case verdicts:	
- test case does not apply to the test object	: N/A
- test object does meet the requirement	: P (Pass)
- test object does not meet the requirement	: F (Fail)
Testing	: -
Date of receipt of test item	: 2013-10-14
Date (s) of performance of tests	: 2013-10-14 to 2013-12-13

General remarks:

The test results presented in this report relate only to the object tested.
This report shall not be reproduced, except in full, without the written approval of the Issuing testing laboratory.

"(See Enclosure #)" refers to additional information appended to the report.

"(See appended table)" refers to a table appended to the report.

Throughout this report a comma / point is used as the decimal separator.

Manufacturer's Declaration per sub-clause 4.2.5 of IEC60335-1:

The application for obtaining a CB Test Certificate includes more than one factory location and a declaration from the Manufacturer stating that the sample(s) submitted for evaluation is (are) representative of the products from each factory has been provided.....: Yes Not applicable

When differences exist; they shall be identified in the General product information section.

Name and address of factory (ies).....: Suzhou Bortly Hardware Illumination Electric Appliance Co. Ltd
Fenyue Road, Fenu Economy & Technology Development Zone
Wujiang City, Jiangsu, China

General product information:

The product is plug-in adaptor which could not be inserted to socket-outlets which complies with standard datasheet III. The plug and socket-outlet portions of the adaptor are designed based on VII of CEE7 and III of CEE7 with small deviations. For the deviation, see schematic on page 45.

Product data –1103/DEORPC
Design : 5 fold

Product data –1100/DEORPC
Design : 5 fold

Product data –1203/DEOUPC
Design : 4 fold and 2 USB ports

Product data –1202/DEOUPC
Design : 4 fold and 2 USB ports

This powercube may not be available in countries where Class 0 socket-outlets are commonly used, such as Denmark (DK), Finland (FI), The Netherlands (NL), Portugal (PT), Spain (ES) and Sweden (SE). Insertion into Class 0 socket-outlets can lead to hazardous situations.

Remark:

The original test report 3141761.50, related certificate 3141761.01 was modified on April 10, 2014 to include the following changes:

1. Add the applicant name in the marking: 'Allocacoc B.V.';
2. Add the applicant address in the marking: 'Rotterdamseweg 386 B1, 2629HG Delft, the Netherlands';
3. Add the type 1100/DEORPC and 1202/DEOUPC, they are as same as 1103/DEORPC and 1203/DEOUPC, just with different Packaging.

After review, we are of opinion that no additional test should be performed products again necessary.

Correction: page 5 1203/DEOUPC to 1202/DEOUPC, 1200/DEOUPC to 1202/DEOUPC on 2016.07.08

IEC 60884-1			
Clause	Requirement + Test	Result - Remark	Verdict
8	MARKING		
8.1	Accessories marked as follows:		
	- rated current (A)	16	P
	- rated voltage (V)	250	P
	- symbol for nature of supply	~	P
	- manufacturer's or responsible vendor's name ..	Allocacoc	P
	- type reference	1100/DEORPC, 1202/DEOUPC, 1103/DEORPC and 1203/DEOUPC	P
	- degree of protection (first characteristic numeral) if higher than 2.....		N/A
	- degree of protection (second characteristic numeral) if higher than 0.....		N/A
	- degree of protection (first characteristic numeral) higher than 4 for fixed socket outlet in which case the second characteristic numeral shall also be marked		N/A
	- degree of protection (second characteristic numeral) higher than 2 for fixed socket outlet in which case the first characteristic numeral shall also be marked		N/A
	Socket-outlets with screwless terminals marked with the following:		
	- the length of insulation to be removed		N/A
	- an indication of the suitability to accept rigid conductors only (if any)		N/A
8.2	Symbols used: as required in the standard		P
	Marking for the nature of supply placed next to the marking for rated current and rated voltage		P
8.3	Marking of fixed socket-outlets placed on the main part:		
	- rated current, rated voltage and nature of supply		N/A
	- identification mark of the manufacturer or of the responsible vendor		N/A
	- length of insulation to be removed, if any		N/A
	- indication of the suitability to accept rigid conductors only for screwless terminals for those socket-outlets having this restriction		N/A
	- type reference		N/A

IEC 60884-1			
Clause	Requirement + Test	Result - Remark	Verdict
	Cover plates necessary for safety purposes and intended to be sold separately: marked with the manufacturer's or responsible vendor's name and type reference		N/A
	IP code, if applicable: marked so as to be easily discernible		N/A
	Fixed socket-outlets classified according to item b) of 7.2.5: identified by a triangle visible after installation unless they have an interface configuration different from that used in normal circuits		N/A
8.4	Plugs and portable socket-outlets: marking specified in 8.1, other than the type reference, easily discernible		P
	Plugs and portable socket-outlets for equipment of class II not marked with the symbol for class II construction		N/A
8.5	Neutral terminals: N		N/A
	Earthing terminals: [earth symbol]		N/A
	Markings not placed on screws or other easily removable parts		N/A
	Terminals for conductors not forming part of the main function of the socket-outlet:		
	- clearly identified unless their purpose is self-evident, or		N/A
	- indicated in a wiring diagram fixed to the accessory		N/A
	Identification of such terminals may be achieved by:		
	- their being marked with graphical symbols according to IEC 60417-2 or colours and/or alphanumeric system, or		N/A
	- their being marked with their physical dimensions or relative location		N/A
8.6	Surface-type mounting boxes forming an integral part of socket-outlets having an IP code higher than IP4X, or higher than IPX2, the IP code marked on the outside of its associated enclosure so as to be easily discernible		N/A
8.7	Indication of which position or with which special provision the declared IP of flush-type and semi-flush-type fixed socket-outlets having IP>X0 is ensured		N/A
8.8	Marking durable and clearly legible with normal or corrected vision, without additional magnification. Test: 15 s with water and 15 s with petroleum spirit		P

IEC 60884-1			
Clause	Requirement + Test	Result - Remark	Verdict
9	CHECKING OF DIMENSIONS		
9.1	Accessories and surface-type mounting boxes comply with the appropriate standard sheets and corresponding gauges, if any	see Annex datasheet for plug and socket-outlet datasheet on pages 45 to 47	P
	Insertion of plugs into fixed or portable socket-outlets ensured by their compliance with the relevant standard sheets		P
	Compliance checked by measurement and by means of gauges with manufacturing tolerances as shown in table 2		P
9.2	It is not possible to engage a plug with:		
	- a socket-outlet having a higher voltage rating or a lower current rating;		P
	- a socket-outlet with a different number of live poles (exception admitted provided that no dangerous situation can arise);		P
	- a socket-outlet with earthing contact, if the existing plug of the present national system is a plug for class 0 equipment;		N/A
	Engagement of an existing plugs on the present national system for equipment of class 0 or of class I with a socket-outlet exclusively designed to accept plugs for class II equipment		P
	Impossibility of insertion checked by applying a gauge, for 1 min, with a force of:		
	- 150 N (rated current \leq 16A);		P
	- 250 N (rated current $>$ 16A)		N/A
	Accessories with elastomeric or thermoplastic material: test carried out at $(35 \pm 2) ^\circ\text{C}$		P
9.3	Deviations from standard sheets made only if they provide technical advantage and do not affect the purpose and safety of accessories complying with standard sheet	see Annex datasheet for details	P
10	PROTECTION AGAINST ELECTRIC SHOCK		
10.1	Live parts not accessible, even after removal of parts which can be removed without the use of a tool for:		
	Fixed socket-outlets		N/A
	Plugs when the plug is in partial or complete engagement with a socket-outlet		P
	Test with test probe B of IEC 61032		P

IEC 60884-1			
Clause	Requirement + Test	Result - Remark	Verdict
	Accessories with elastomeric or thermoplastic material: additional test carried out at (35 ± 2) °C with test probe 11 of IEC 61032 (75 N for 1 min)		P
	During the test: accessories not deform and no live parts accessible		P
	Plugs and portable socket-outlets pressed with a force of 150 N for 5 min as shown in figure 8: specimens not show deformation		P
10.2	Accessible parts (with exception of small screws and the like for fixing main parts and covers or cover plates): made of insulating material		P
	Cover or cover plates of fixed socket-outlets and accessible parts of portable socket-outlets: made of metal if the requirements of 10.2.1 or 10.2.2 are fulfilled		N/A
10.2.1	Accessible metal parts or accessible metal parts protected by supplementary insulation made by insulating linings or insulating barriers		N/A
	Insulating linings or insulating barriers cannot be removed without being permanently damaged		N/A
	Insulating linings or insulating barriers cannot be replaced in an incorrect position and, if they are omitted, accessories are rendered inoperable or manifestly incomplete		N/A
	There is no risk of accidental contact between live parts and metal covers or cover plates		N/A
10.2.2	Accessible metal parts are reliably connected, through a low-resistance connection, to the earth during fixing		N/A
10.3	Contact between a pin of a plug and a live socket-contact of a socket-outlet not possible while any other pin is accessible		P
	Compliance checked by manual test and by means of gauges with tolerances as specified in table 2		P
	Accessories with elastomeric or thermoplastic material: test carried out at (35 ± 2) °C		P
	Socket-outlets with enclosure or bodies of rubber or polyvinyl chloride: test carried out with a force of 75 N for 1 min		N/A
	Fixed socket-outlets provided with metal covers or cover plates: clearance of at least 2 mm required between a pin and a socket-contact when another pin(s) is(are) in contact with the metal covers or cover plates (mm).....:		N/A
10.4	External parts of plugs made of insulating material		P

IEC 60884-1			
Clause	Requirement + Test	Result - Remark	Verdict
	Overall dimensions of rings around pins not exceed 8 mm concentric with respect to the pin		N/A
10.5	Shuttered socket-outlets: live parts not accessible, without a plug in engagement, with the gauges shown in figure 9 and 10		P
	Live contacts automatically screened when the plug is withdrawn		P
	Shutters so designed that a plug is inserted with the same movement in a socket outlet with shutters as in a socket-outlet without shutters		P
	Means cannot easily be operated by anything other than a plug and not depend upon parts which are liable to be lost		P
	Gauge of figure 9, applied to the entry holes corresponding to live contacts with a force of 20 N, for approximately 5 s, successively in three directions, does not touch live parts		P
	Steel gauge of figure 10, applied to the entry holes corresponding to live contacts with a force of 1 N for approximately 5 s, in three directions, does not touch live parts		P
	Accessories with elastomeric or thermoplastic material: test carried out at $(35 \pm 2) ^\circ\text{C}$		P
10.6	Earthing contacts of a socket-outlet designed that they cannot be deformed by the insertion of a plug		P
	Test plug inserted into the socket-outlet with a force of 150 N for 1 min		
	After this test: socket-outlet still comply with the requirements of clause 9		P
10.7	Socket-outlet with or without lid with increased protection: live parts not accessible		N/A
	Test wire of 1 mm diameter (figure 10) applied with a force of 1 N on all accessible surfaces does not touch live parts		N/A
	Accessories with elastomeric or thermoplastic material: test carried out at $(35 \pm 2) ^\circ\text{C}$		N/A
	Socket-outlet tested without a plug inserted with the lid, if any, open		N/A
11	PROVISION FOR EARTHING		
11.1	Earth connection made before the current-carrying contacts of the plug become live		P
	Current-carrying pins are separated before the earth connection is broken		P

IEC 60884-1			
Clause	Requirement + Test	Result - Remark	Verdict
11.2	Earthing terminals of rewirable accessories comply with clause 12		N/A
	Earthing terminals of the same size as the corresponding terminals for the supply conductors		N/A
	Earthing terminals of rewirable accessories: internal		N/A
	Earthing terminals of fixed socket-outlets: fixed to the base or to a part reliably fixed to the base		N/A
	Earthing contacts of fixed socket-outlets:		
	- fixed to the base, or		N/A
	- fixed to the cover (reliably connected to the earthing terminals; contact pieces silver plated or with adequate protection)		N/A
	Parts of earthing circuit in one piece or reliably connected by riveting, welding, or the like		P
11.3	Accessible metal parts of fixed socket-outlets: permanently and reliably connected to the earthing terminal		N/A
11.4	Socket-outlets, having an IP>X0, with enclosure of insulating material and more than one cable inlet, provided with:		
	- an internal fixed earthing terminal, or		N/A
	- adequate space for a floating terminal (test connection using the type of terminal specified by the manufacturer), unless		N/A
	- earthing terminal of socket-outlet itself allows the connection of an incoming and an outgoing earthing conductor		N/A
11.5	Connection between earthing terminal and accessible metal parts: of low resistance		N/A
	Test current equal to 1,5 times the rated current or 25 A (A)		—
	Resistance not exceed 0,05 Ω (Ω)		N/A
11.6	Fixed socket-outlets according to item b) of 7.2.5: earthing socket contact and its terminal electrically separated from any metal mounting means or other exposed conductive parts which may be connected to the protective earthing circuit of the installation		N/A
12	TERMINALS AND TERMINATIONS		
	All the test on terminals, with the exception of the tests of 12.3 11 and 12.3.12, made after the test of clause 16		N/A
12.1	General		

IEC 60884-1			
Clause	Requirement + Test	Result - Remark	Verdict
12.1.1	Rewirable fixed socket-outlets provided with screw-type terminals or with screwless terminals		N/A
	Rewirable plugs and portable socket-outlets provided with terminals with screw clamping		N/A
	Pre-soldered flexible conductors used: pre-soldered area outside the clamp area of screw-type terminals		N/A
	Clamping means of terminals: not serve to fix any other components		N/A
12.1.2	Non-rewirable accessories provided with soldered, welded, crimped or equally effective permanent connections (termination)	welded connection and soldered connection	P
	Screwed or Snap-On connections not used		P
	Connections made by crimping a pre-soldered flexible conductor not permitted		N/A
12.2	Terminals with screw clamping for external copper conductors		
12.2.1	Accessories provided with terminals which allows the proper connection of copper conductors as shows in table 3		N/A
	Rated current (A); Type of accessories		—
	Type of conductor (rigid / flexible)		—
	Smallest / largest cross-sectional area (mm ²)		—
	Diameter of the largest conductor (mm)		—
	Figure of terminal		—
	Minimum diameter D (minimum dimensions) of conductor space: required (mm); measured (mm):		N/A
12.2.2	Terminals allow the conductor to be connected without special preparation		N/A
12.2.3	Terminals have adequate mechanical strength		N/A
	Screws and nut for clamping the conductors have metric ISO thread or a comparable thread		N/A
	Screws not of soft metal such as zinc or aluminium		N/A
12.2.4	Terminals resistant to corrosion		N/A
12.2.5	Terminals clamp the conductor(s) without undue damage	See appended table 12.2.5	N/A
	During the test: conductor not slip out, no break near clamping unit and no damage		N/A
12.2.6	Terminals clamp the conductor reliably between metal surfaces	See appended table 12.2.6	N/A
	During the test: conductor not move noticeably		N/A

IEC 60884-1			
Clause	Requirement + Test	Result - Remark	Verdict
12.2.7	Terminals designed or placed that the conductor cannot slip out while the clamping screws or nuts are tightened	See appended table 12.2.7	N/A
	After the test: no wire of the conductor escaped from the clamping unit		N/A
12.2.8	Terminals not work loose from their fixing to accessories		N/A
	Torque test (screws and nuts tightened and loosened 5 times):		
	- rated current (A)		—
	- copper conductor of the largest cross-sectional area (mm ²) (table 3)		—
	- type of conductor (solid or stranded)		—
	- torque (Nm) (table 6 or appropriate figures 2, 3 or 4)		—
	During the test: terminals not work loose and show no damage		N/A
12.2.9	Clamping screws or nuts of earthing terminals: adequately locked against accidental loosening, not possible to loosen them without the aid of a tool		N/A
12.2.10	Earthing terminals: no risk of corrosion		N/A
	Body of brass or other metal no less resistant to corrosion		N/A
	The body is a part of a frame or enclosure of aluminium alloy: precautions are taken to avoid the risk of corrosion		N/A
12.2.11	Pillar terminals: distance <i>g</i> no less than the value specified in figure 2: required (mm); measured (mm)		N/A
	Mantle terminals: distance <i>g</i> no less than the value specified in figure 5: required (mm); measured (mm)		N/A
12.3	Screwless terminals for external copper conductors		
12.3.1	Screwless terminals of the type suitable for:		
	- for rigid copper conductors only, or		N/A
	- for both rigid and flexible copper conductors (tests carried out with rigid and then repeated with flexible conductors)		N/A
12.3.2	Screwless terminals provided with two clamping units each allowing the proper connection of rigid or of rigid and flexible conductors having nominal cross-sectional areas from 1,5 up to 2,5 mm ² (table 7)		N/A

IEC 60884-1			
Clause	Requirement + Test	Result - Remark	Verdict
	Two conductors to be connected: each conductor introduced in a separate clamping unit		N/A
12.3.3	Screwless terminals allow the conductor to be connected without special preparation		N/A
12.3.4	Parts of screwless terminals intended for carrying current of materials as specified in 26.5		N/A
12.3.5	Screwless terminals clamp specified conductors with sufficient contact pressure without undue damage to the conductor		N/A
	Conductor clamped between metal surfaces		N/A
12.3.6	It is clear how the connection and disconnection of the conductors is to be made		N/A
	Disconnection of a conductor require an operation, other than a pull, so that can be made manually with or without a general-purpose tool		N/A
	It is not possible to confuse the opening intended for the use of a tool with the opening intended for the conductor		N/A
12.3.7	Screwless terminals intended for the interconnection of two or more conductors:		
	- the clamping of one of the conductors is independent of the clamping of the other conductor(s)		N/A
	- during the connection or disconnection the conductors can be connected or disconnected either at the same time or separately		N/A
	- each conductor introduced in a separate clamping unit.		N/A
	- it is possible to clamp securely any number of conductors up to the maximum as designed. Number of conductors; Nominal cross-sectional area (mm ²)		N/A
12.3.8	Screwless terminals of fixed socket-outlets: adequate insertion obvious and over-insertion prevented		N/A
12.3.9	Screwless terminals properly fixed to the socket-outlets		N/A
	Not work loose when conductors are connected or disconnected		N/A
	Self-hardening resins used to fix terminals not subject to mechanical stress		N/A
12.3.10	Screwless terminals withstand mechanical stresses occurring in normal use	See appended table 12.3.10	N/A
	During application of the pull conductor not come out of the terminal		N/A

IEC 60884-1			
Clause	Requirement + Test	Result - Remark	Verdict
	Additional test with apparatus shown in figure 11	See appended table 12.3.10	N/A
	During the test: conductors not moved noticeably in the clamping unit		N/A
	After these tests: neither terminals nor clamping means have worked loose and conductors show no deterioration		N/A
12.3.11	Screwless terminals withstand electrical and thermal stresses occurring in normal use	See appended table 12.3.11	N/A
	After the test: inspection show no changes		N/A
	Repetition of mechanical strength test according to 12.3.10	See appended table 12.3.11	N/A
	During application of the pull conductor not come out of the terminal		N/A
	Additional test with apparatus shown in figure 11	See appended table 12.3.11	N/A
	During the test: conductors not moved noticeably in the clamping unit		N/A
	After these tests: neither terminals nor clamping means have worked loose and conductors show no deterioration		N/A
12.3.12	Screwless terminals: connected rigid solid conductor remains clamped, even when deflected during normal installation	See appended table 12.3.12	N/A
13	CONSTRUCTION OF FIXED SOCKET-OUTLETS		N/A
14	CONSTRUCTION OF PLUGS AND PORTABLE SOCKET-OUTLETS		
14.1	Non-rewirable portable accessories:		
	flexible cable cannot be separated from the accessory without making it permanently useless		N/A
	Accessory cannot be opened by hand or by using a general purpose tool, for example a screwdriver used as such		N/A
14.2	Pins of portable accessories: adequate mechanical strength		P
	Test for pins not solid (made after clause 21): force of 100 N exerted on the pin, according to figure 14, for 1 min by means of a steel rod \varnothing 4,8 mm		
	During the application of the force: reduction of the dimension of the pin not exceed 0,15 mm		N/A
	After removal of the rod: dimensions of the pin not changed by more than 0,06 mm		N/A
14.3	Pin(s) and contacts of portable accessories :		

IEC 60884-1			
Clause	Requirement + Test	Result - Remark	Verdict
	- locked against rotation;		P
	- not removable without dismantling the plug;		P
	- adequately fixed in the body of the plug		P
	Earthing or neutral pins or contacts of plugs: not possible to arrange in an incorrect position		P
	The pin(s) of portable accessories constructed in such a way that the mechanical strength of the pin(s) does not depend on the plastic material		P
	Compliance is checked by inspection and in case of doubt by the tests of 14.2 and Clause 21 on a new set of specimens without plastic		P
	Surfaces of plug pin(s) smooth and free from burrs or sharp edges and other irregularities which could cause damage or excessive wear to corresponding socket contacts or shutters		P
14.4	Earthing contacts, phase contacts and neutral contacts of portable socket-outlets :		
	- locked against rotation		P
	- removable only with the aid of a tool, after dismantling the socket-outlet		P
	In addition, for single portable socket-outlets compliance is checked by the test of 24.2		N/A
14.5	Socket-contact assemblies: sufficient resilience		P
	Parts of socket-contact assemblies:		
	- are not of insulating material except ceramic, or other material with no less suitable characteristics		P
	- ensure metallic contacts at least on two opposing sides of each pin		P
	Contact pressure of the contact tube does not depend on soldered connection only		P
14.6	Pins and socket-contacts: resistant to corrosion and abrasion		P
	Socket contacts and pin(s) of socket-outlets, which are made of copper or copper alloy, as specified in 26.5, are considered as complying with this requirement.		P
14.7	Enclosures of rewirable portable accessories: completely enclose terminals and ends of flexible cable		N/A
	Construction is unlikely that:		
	- cores not pressed against each other causing damage		N/A

IEC 60884-1			
Clause	Requirement + Test	Result - Remark	Verdict
	- cores of live conductor not pressed against accessible metal parts		N/A
	- core of earthing conductor not pressed against live parts		N/A
14.8	Rewirable portable accessories: terminal screws or nuts cannot become loose and fall out of position and establish an electrical connection between live parts and earthing terminal or metal parts		N/A
14.9	Rewirable portable accessories with earthing contact: ample space for slack of earthing (test)		N/A
	Non-rewirable non-moulded-on accessories with earthing contact: current-carrying conductors stressed before the earthing conductor if the flexible cable slips in its anchorage		P
14.10	Terminals of rewirable portable accessories and terminations of non-rewirable portable accessories: located and shielded that loose wires not present a risk of electric shock		P
	Non-rewirable moulded-on portable accessories: provided with means to prevent loose wires of a conductor from reducing the minimum isolation distance requirements		N/A
14.10.1	Rewirable accessories: test with 6 mm free wire		
	free wire of a conductor connected to a live terminal not touch any accessible metal part or able to emerge from the enclosure		N/A
	free wire of a conductor connected to an earthing terminal not touch a live part		N/A
14.10.2	Non-rewirable, non-moulded-on accessories: test with a free wire of length equivalent to the maximum designed stripping length declared by the manufacturer plus 2 mm		
	free wire of a conductor connected to a live termination not touch any accessible metal part or reduce creepage distance and clearance below 1,5 mm to the external surface		P
	free wire of a conductor connected to an earth termination not touch any live part		P
14.10.3	Non-rewirable, moulded-on accessories:		
	Verification of means to prevent stray wires reducing the minimum distance through insulation to external accessible surface below 1,5 mm		N/A
14.11	Rewirable portable accessories:		
	- clear how relief from strain and prevention of twisting is intended to be effected		N/A

IEC 60884-1			
Clause	Requirement + Test	Result - Remark	Verdict
	- cord anchorage, or at least part of it, integral with or securely fixed to one of the component parts of the plug or portable socket-outlet		N/A
	- makeshift methods not used		N/A
	- cord anchorage suitable for the different types of flexible cable which may be connected to it; screws, if any: not serve to fix any other component		N/A
	- cord anchorages: of insulating material or provided with an insulating lining fixed to the metal parts		N/A
	- metal parts of cord anchorages, including clamping screws: insulated from the earthing circuit		N/A
14.12	Rewirable portable accessories and non-rewirable non-moulded on portable accessories: it is not possible to remove covers, cover-plates or parts of them intended to ensure protection against electric shock without the use of a tool		P
14.13	Covers of portable socket-outlets: bushings for entry holes for the pins not removable from the outside or detachable inadvertently from the inside		N/A
14.14	Screws intended to allow access to interior of the accessory: captive		N/A
14.15	Engagement face of plugs: no projections		P
14.16	Engagement face of portable socket-outlets: no projection		P
14.17	Portable accessories of IP>20: enclosed according to their IP classification		N/A
	Plugs having IP>20: adequately enclosed with the exception of the engagement face		N/A
	Portable socket-outlets having IP>20: adequately enclosed without a plug in engagement		N/A
	Lid springs (if any): of corrosion-resistant material (bronze or stainless steel)		N/A
14.18	Portable socket-outlets: means for suspension from a wall or other mounting surfaces not allow access to live parts		N/A
	No free openings between space intended for suspension means by which the socket-outlet is fixed to the wall, or other mounting surface and live parts		N/A
14.19	Combinations of portable accessories and switches, circuit-breakers or other devices comply with relevant individual IEC standards, if relevant combined product standard does not exist	USB charger: IEC/EN 60950-1	P

IEC 60884-1			
Clause	Requirement + Test	Result - Remark	Verdict
14.20	Portable accessories: not integral part of lampholders		P
14.21	Plugs for equipment of class II:		
	- rewirable or non-rewirable		N/A
	- if part of a cord set: provided with a connector for equipment of class II		N/A
	- if part of a cord extension set: provided with a portable socket-outlet for equipment of class II		N/A
14.22	Components (switches and fuses) incorporated in accessories: comply with the relevant IEC standard as far as it applies		
	Components incorporated in portable accessories so rated, or so protected, that overloading of either the component or the plug or the socket-outlet portion cannot occur in normal use		P
	Requirements for switches incorporated in portable accessories are detailed in Annex D	See appended table 14.22	N/A
	For portable socket-outlets and rewirable plugs the incorporated overcurrent protective device in the accessory shall have a rated current equal to or less than the rated current of the accessory		N/A
	Any other component(s), such as switches or control devices, have a rated current not less than (rated current referred to resistive load):		
	- the rated current of the accessory or		N/A
	- the rated current of the incorporated overcurrent protective device, if any		N/A
	For non-rewirable plugs, any other incorporated component(s), such as switches or control devices, have a rated current not less than:		
	- the test current for the combination of the accessory and the cable as indicated in Table 20, for Clause 21, or		N/A
	- the rated current of the incorporated overcurrent protective device, if any		N/A
	Any incorporated component(s) have a rated voltage not less than the rated voltage of the accessory		P
	Compliance is checked by inspection and, if necessary, by testing the component according to the relevant IEC standard	see appended table 14.22	P
14.23	Plug-in equipment: not cause overheating of the pins or impose undue strain		P
	Plugs with rating above 16 A and 250 V: not integral part of other equipment		P

IEC 60884-1			
Clause	Requirement + Test	Result - Remark	Verdict
	Tests for two-pole plugs, with or without earthing contact, with rating up to and including 16 A and 250 V (plug of equipment inserted into a fixed socket-outlet complying with this standard):		
14.23.1	Socket-outlet connected to a supply voltage equal to 1,1 times the highest rated voltage of the equipment (V)	275	—
	Temperature rise of the pins after 1 h not exceed 45 K (K)	< 40	P
14.23.2	Additional torque applied to the socket-outlet in order to maintain the engagement face in the vertical plane not exceed 0,25 Nm (Nm)	plug specified designed which could not be inserted into fixed socket-outlet which complies with III of CEE7	N/A
14.24	Plugs can easily be withdrawn by hand from the relevant socket-outlets		P
	Gripping surfaces are so designed that the plug can be withdrawn without having to pull the flexible cable		P
14.25	Membranes in inlet openings of portable accessories: meet the requirements of 13.22 and 13.23		N/A
14.26	Rewirable portable socket-outlets which can be assembled and wired for normal use after their rear part has been fixed onto a surface comply both with the requirements for portable socket-outlets and with the following additional requirements for surface fixed socket-outlets:		
	- provision for earthing: 11.2, 11.3, 11.6;		N/A
	- terminals and terminations: 12.2.1;		N/A
	- construction of fixed socket-outlets: Clause 13;		N/A
	- resistance to ageing, protection provided by enclosures, and resistance to humidity: 16.2.1, 16.2.2;		N/A
	- temperature rise: Clause 19;		N/A
	- mechanical strength: Clause 24;		N/A
	- resistance to heat: Clause 25;		N/A
	- creepage distances, clearances and distances through sealing compound: Clause 27;		N/A
	- resistance of insulating material to abnormal heat, to fire and to tracking: 28.1.1, glow-wire test		N/A
15	INTERLOCKED SOCKET-OUTLETS		N/A
16	RESISTANCE TO AGEING, PROTECTION PROVIDED BY ENCLOSURES, AND RESISTANCE TO HUMIDITY		

IEC 60884-1			
Clause	Requirement + Test	Result - Remark	Verdict
16.1	Resistance to ageing		
	Accessories are resistant to ageing		P
	For accessories having a lid, the lid is closed during the test		N/A
	Portable socket-outlets: the plug of the same system having the same rated current as the socket-outlet inserted into the socket-outlet during the test		P
	Accessories subjected to a test in a heating cabinet at $(70 \pm 2) ^\circ\text{C}$ for seven days (168 h)	80 °C	P
	After the tests, the specimens show:		
	- no crack visible with normal or corrected vision without additional magnification		P
	- no sticky or greasy material		P
	- no trace of cloth (forefinger pressed with 5 N)		P
	- no damage		P
	Portable socket-outlets: contact pressure of the contact assembly checked as specified in subclause 22.2 with the single-pin gauge		P
16.2	Protection provided by enclosures		
	Enclosures provide a degree of protection in accordance with the IP designation of the accessory	IP20	P
16.2.1	Protection against access to hazardous parts and against harmful effects due to ingress of solid foreign objects		
	Accessories and their enclosures provide a degree of protection against access to hazardous parts and against harmful effects due to ingress of solid foreign objects		P
	Fixed socket-outlets: mounted as in normal use on a vertical surface		N/A
	Flush-type and semi-flush type socket-outlets: mounted in an appropriate box according to the manufacturer's instructions		N/A
	Accessories with screwed glands or membranes fitted with flexible cables within the range specified in table 3:		
	- largest cross-sectional area (mm ²); type of cable (table 17)		—
	- smallest cross-sectional area (mm ²); type of cable (table 17)		—
	Glands tightened with a torque equal to 2/3 of the torque applied during the test of 24.6 (Nm)		—

IEC 60884-1			
Clause	Requirement + Test	Result - Remark	Verdict
	Screws of the enclosure tightened with a torque equal to 2/3 of the torque given in table 6 (Nm) .:		—
16.2.1.1	Protection against access to hazardous parts		
	Appropriate test performed as specified in IEC 60529 (see also clause 10)		P
16.2.1.2	Protection against harmful effects due to ingress of solid foreign objects		
	Appropriate test performed as specified in IEC 60529		P
	Test on accessories with IP5X (considered to be of category 2): dust not penetrated in a quantity to interfere with satisfactory operation or to impair safety		N/A
	Test on accessories with IP6X (considered to be of category 1): dust do not penetrate		N/A
16.2.2	Protection against harmful effects due to ingress of water		
	Accessories and their enclosures provide a degree of protection against harmful effects due to ingress of water in accordance with their IP classification		N/A
	Appropriate test performed as specified in IEC 60529 under the following conditions:		
	Flush-type and semi-flush type socket-outlets: fixed in a vertical test wall using an appropriate box according to the manufacturer's instructions		N/A
	Accessory suitable to be installed on a rough wall: test wall according to figure 15 is used		N/A
	Surface-type socket-outlets mounted as for normal use in a vertical position and fitted with cables (having conductors of the largest and smallest nominal cross-sectional area given in table 3) or conduits or both in accordance with the manufacturer's instructions:		
	- largest cross-sectional area (mm ²); type of cable (table 17)		—
	- smallest cross-sectional area (mm ²); type of cable (table 17)		—
	Portable socket-outlets tested on a plain, horizontal surface in a position as in normal use and fitted with flexible cables (having conductors of the largest and smallest nominal cross-sectional area given in table 3) according to table 17:		
	- largest cross-sectional area (mm ²); type of cable (table 17)		—
	- smallest cross-sectional area (mm ²); type of cable (table 17)		—
	Screws of enclosure tightened with a torque equal to 2/3 of the torque given in table 6 (Nm)		—

IEC 60884-1			
Clause	Requirement + Test	Result - Remark	Verdict
	Glands tightened with a torque equal to 2/3 of the torque applied during the test of 24.6 (Nm)		—
	Accessory with drain holes opened during the test: any accumulation of water proved by inspection		N/A
	Socket-outlets tested without a plug in engagement		N/A
	Plugs tested when in full engagement with:		
	- a fixed socket-outlets		N/A
	- a portable socket-outlets		N/A
	of the same system and with the same degree of protection against harmful effects due to ingress of water		—
	Specimens withstand an electric strength test specified in 17.2 which is started within 5 min of completion of the IP test		N/A
16.3	Resistance to humidity		
	Accessories proof against humidity which may occur in normal use		P
	Compliance checked by a humidity treatment carried out in a humidity cabinet containing air with relative humidity maintained between 91 % and 95 %		P
	Specimens kept in the cabinet for:		
	- two days (48 h) for accessories having IPX0		P
	- seven days (168 h) for accessories having IP>X0		N/A
	After this treatment the specimens show no damage		P
17	INSULATION RESISTANCE AND ELECTRIC STRENGTH		
17.1	Insulation resistance measured 1 min after application of 500 V d.c.	See appended table 17.1	P
17.2	Electric strength: a.c. test voltage applied for 1 min	See appended table 17.2	P
18	OPERATION OF EARTHING CONTACTS		
	Earthing contacts provide adequate contact pressure and not deteriorate in normal use		P
	Compliance checked by the tests of clauses 19 and 21		P
19	TEMPERATURE RISE		
	Accessories constructed that they comply with the following temperature rise test		
	Non-rewirable accessories are tested as delivered		P

IEC 60884-1			
Clause	Requirement + Test	Result - Remark	Verdict
	In the case of multiple socket-outlets, the test is carried out on one socket-outlet of each type and current rating with the test current as specified in Table 20 passed through that one socket-outlet	See appended tables	P
	The temperature rise of the terminals, terminations and clamping units according to Figure 44 determined by means of thermocouples do not exceed 45 K	See appended tables	P
19.1	Socket-outlets and plugs are tested as follows:		
	Socket-outlets tested using a test plug with brass pins having the minimum specified dimensions	See appended table 19.1	P
	For this test the temperature rise is measured on the terminals and terminations.		P
	Plugs tested with clamping units having dimensions specified in Figure 44 fitted on each live pin and earthing pin, if any	See appended table 19.1	P
	Plugs having lateral earthing contacts and resilient earthing contacts tested using a fixed socket-outlet complying with the standard and having as near to-average characteristics as can be selected, but with minimum size of the earthing pin, if any	See appended table 19.1	P
19.2	Fixed socket-outlets of a socket-outlet and fused plug system are tested as follows:		
	a) For a single socket-outlet the plug is inserted into the socket-outlet and 70 % of the test current is passed through the plug	See appended table 19.2	N/A
	The balance of the total test current is passed, simultaneously through a looped connection, connected to the socket-outlet terminals		N/A
	The total nominal load on the supply cable is passed for 60 min	See appended table 19.2	N/A
	b) For a multiple socket-outlet a plug is inserted into one socket-outlet and 70 % of the test current is passed	See appended table 19.2	N/A
	A second plug is inserted into another socket-outlet and the balance of the total test current is passed simultaneously through this plug.....:	See appended table 19.2	N/A
	The total nominal load on the supply cable is passed for 60 min.	See appended table 19.2	N/A
19.3	Portable socket-outlets and rewirable plugs with incorporated components are tested by the following two tests:		
	– with a current which is equal to the test current as indicated in Table 20, for Clause 19	See appended table 19.3	P
	– with a current which is equal to the rated current of the portable accessory or the rated current of the component(s), whichever is the lower	See appended table 19.3	P

IEC 60884-1			
Clause	Requirement + Test	Result - Remark	Verdict
	Non-rewirable plugs with incorporated components are tested by the following two tests:		
	– with a current which is equal to the test current for the combination of the plug and the cable as indicated in Table 20, for Clause 19	See appended table 19.3	N/A
	– with a current which is equal to the test current for the combination of the plug and the cable as indicated in Table 20, for Clause 21, or the rated current of the component(s), whichever is the lower	See appended table 19.3	N/A
20	BREAKING CAPACITY		
	Accessories have adequate breaking capacity		P
	Compliance checked by testing:		
	- socket-outlets;	See appended table 20	P
	- plugs with pins which are not solid	See appended table 20	N/A
	Multiple socket-outlets: test carried out on one socket-outlet of each type and current rating		P
	During the test: no sustained arcing occur		P
	After the test:		
	- specimens show no damage impairing their further use;		P
	- entry holes for the pins not show any damage which may impair the safety		P
21	NORMAL OPERATION		
	Accessories withstand without excessive wear or other harmful effect, the mechanical, electrical and thermal stresses occurring in normal use		P
	Compliance checked by testing:		
	- socket-outlets;	See appended table 21	P
	- plugs with resilient earthing socket-contacts;	See appended table 21	P
	- plugs with pins which are not solid	See appended table 21	N/A
	Test performed according to the procedure specified in Figure 43; point of Figure 43 at which the test program has begun (1, 2, 3)	1	—
	Test current passed:		
	- during each insertion and withdrawal of the plug ($I_n \leq 16A$)		P
	- during alternate insertion and withdrawal, the other insertion and withdrawal being made without current flowing ($I_n > 16A$)		N/A

IEC 60884-1			
Clause	Requirement + Test	Result - Remark	Verdict
	Multiple socket-outlets: test carried out on one socket-outlet of each type and current rating		P
	During the test: no sustained arcing occur		P
	After the test the specimens do not show:		
	- wear impairing their further use;		P
	- deterioration of enclosures, insulating lining or barriers;		P
	- damage to the entry holes for the pins, that might impair proper working;		P
	- loosening of electrical or mechanical connections;		P
	- seepage of sealing compound		N/A
	Shuttered socket-outlets: gauges of figure 9 and 10 applied to the entry holes corresponding to live contacts do not touch live parts when they remain under the relevant forces	See appended table 21	P
	Temperature-rise test (requirements of clause 19)	See appended table 21	P
	Electric strength (sub-clause 17.2)	See appended table 21	P
	Pins which are not solid: test according to 14.2		N/A
22	FORCE NECESSARY TO WITHDRAW THE PLUG		
	Construction of accessory does allow the easy insertion and withdrawal of the plug, and prevent the plug from working out of the socket-outlet in normal use		P
22.1	Verification of the maximum withdrawal force	See appended table 22	P
22.2	Verification of the minimum withdrawal force	See appended table 22	P
23	FLEXIBLE CABLES AND THEIR CONNECTIONS		N/A
24	MECHANICAL STRENGTH		
	Accessories, surface mounting boxes, screwed glands and shrouds have adequate mechanical strength		P
24.1	Fixed socket-outlets, portable multiple socket-outlets and surface-type mounting boxes: hammer test described in IEC 60068-2-75 (test EHA), equivalent mass of 250 g	See appended table 24.1	N/A
	After the test: no damage, live parts no become accessible		N/A

IEC 60884-1			
Clause	Requirement + Test	Result - Remark	Verdict
24.2	Portable single socket-outlets and plugs: subjected to test Ec: Rough handling shocks, primarily for equipment-type specimens, procedure 2 of IEC 60068-2-31 (tumbling barrel); number of falls.....:	50 according to IEC 60884-2-5	P
	After the test:		
	- no part become detached or loosened;		P
	- pins no become so deformed that the plug cannot be introduced into a socket-outlet and also fails to comply with the requirements of 9.1 and 10.3;		P
	- pins no turn when a torque of 0,4 Nm is applied for 1 min in each direction		P
	The shutters of socket-outlets tested again according to Clause 21, from paragraph 19 up to paragraph 24 (only the tests of shutters)		P
24.3	Main parts of surface-type socket-outlets: first fixed to a cylinder of rigid steel sheet and then fixed to a flat steel sheet		
	During and after the tests: no damage		N/A
24.4	Portable single socket-outlets, multiple socket-outlets and plugs (elastomeric or thermoplastic material): impact test, weight (1000 ± 2) g, height 100 mm (apparatus shown in fig. 27)		
	Specimens placed in a freezer at (-15 °C ± 2) °C for at least 16 h. After the test: no damage		P
24.5	Portable single socket-outlets and plugs (elastomeric or thermoplastic material): compression test, 300 N for 1 min, position a) and b) (apparatus shown in fig. 8)		
	After the test: no damage		P
24.6	Screwed glands of accessories having IP>20: torque test (1 min)		
	- diameter of test rod (mm)		—
	- type of material (metal / moulded)		—
	- torque (Nm)		—
	After the test: no damage of glands and enclosures of the specimens		N/A
24.7	Plug pins provided with insulating sleeves: 20000 movements, 4 N (apparatus shown in fig. 28)		
	After the test: no damage of pins, insulating sleeve not have punctured or rucked up		N/A
24.8	Shuttered socket-outlets: mechanical test carried out on specimens submitted to the normal operation test according to clause 21		
	Force (40 N / 75 N) applied for 1 min against the shutter of an entry hole by means of one pin (N) :	40	—
	Pin did not come in contact with live parts		P
	After the test: no damage		P

IEC 60884-1			
Clause	Requirement + Test	Result - Remark	Verdict
24.9	Mechanical test for multiple portable socket-outlet: 8 falls on concrete floor with the specimens arranged as shown in figure 29		
	Rewirable multiple socket-outlets: flexible cable of the smallest cross-sectional area specified in table 3	-	—
	After the test: no damage, no part have become detached or loosened		N/A
	Accessories having IP>X0 submitted again to the tests as specified in 16.2		N/A
	The shutters of multiple socket-outlets tested again according to Clause 21, from paragraph 19 up to paragraph 24 (only the tests of shutters)		N/A
24.10	Plugs: pull test to verify the fixation of pins in the body of the plug (new specimens)		
	Maximum withdrawal force (table 16) applied for 1 min on each pin in turn, after the specimen has been placed at (70 ± 2) °C for 1 h (N)	54	—
	After the test: displacement of pins in the body of the plug ≤ 1 mm (mm)	0,3	P
24.11	Barriers of portable socket-outlets having means for suspension on a mounting surface:		
	Force applied for 10 s against the barrier by means of a cylindrical steel rod (1,5 times the maximum plug withdrawal force in 22.1, table 16) (N)		—
	Rod did not pierce the barrier		N/A
24.12	Portable socket-outlets having means for suspension on a mounting surface (pull test):		
	Pull applied to the supply flexible cable for 10 s (force prescribed in 23.2 for checking the flexible cable anchorage) (N)		—
	During the test: no break of the means for suspension on a mounting surface		N/A
24.13	Portable socket-outlets having means for suspension on a mounting surface (pull test):		
	Pull applied to the engagement face of the socket-outlet for 10 s (maximum withdrawal force specified, for the corresponding plug, in table 16) (N)		—
	During the test: no break of the means for suspension on a mounting surface		N/A
24.14	Forces necessary to retain or remove covers, cover-plates or parts of them (accessibility with the test finger to live parts)		
24.14.1	Verification of the retention of covers or cover-plates (fixed socket-outlets)		

IEC 60884-1			
Clause	Requirement + Test	Result - Remark	Verdict
	Force (40 N / 80 N) applied for 1 min perpendicular to the mounting surface (N)		—
	Covers or cover-plates did not come off		N/A
	Test repeated on new specimens with a sheet of hard material, (1 ± 0,1) mm thick, fitted around the supporting frame (fig. 31): covers or cover-plates did not come off		N/A
	After the test: no damage		N/A
24.14.2	Verification of the removal of covers or cover-plates (fixed socket-outlets)		
	Force not exceeding 120 N applied 10 times perpendicular to the mounting / supporting surface: covers or cover-plates came off		N/A
	Test repeated on new specimens with a sheet of hard material, (1 ± 0,1) mm thick, fitted around the supporting frame (fig. 31): covers or cover-plates came off		N/A
	After the test: no damage		N/A
24.14.3	Verification of the retention of covers or cover-plates (plugs and portable socket-outlets)		
	Force 80 N applied for 1 min perpendicular to the mounting surface: covers, cover-plates or parts of them did not come off		P
	Test repeated with a force of 120 N:		
	Rewirable plugs and rewirable portable socket-outlets: covers, cover-plates or parts of them came off but the specimen showed no damage		N/A
	Non-rewirable, non-moulded-on accessories: covers, cover-plates or parts of them came off but the accessories were permanently useless according to 14.1		P
24.15	Force necessary for covers or cover-plates to come off or not to come off (accessibility with the test finger to non-earthed metal parts separated from live parts by creepage distances and clearances according to table 23)		
24.14.1	Verification of the non-removal of covers or cover-plates		
	Force (10 N / 20 N) applied for 1 min in direction perpendicular to the mounting surface (N)		—
	Covers or cover-plates did not come off		N/A
	Test repeated on new specimens with a sheet of hard material, 1 mm ± 0,1 mm thick, fitted around the supporting frame (fig. 31): covers or cover-plates did not come off		N/A
	After the test: no damage		N/A
24.14.2	Verification of the removal of covers or cover-plates		

IEC 60884-1			
Clause	Requirement + Test	Result - Remark	Verdict
	Force not exceeding 120 N applied 10 times in direction perpendicular to the mounting / supporting surface: covers or cover-plates came off		N/A
	Test repeated on new specimens with a sheet of hard material, 1 mm ± 0,1 mm thick, fitted around the supporting frame (fig. 31): covers or cover-plates came off		N/A
	After the test: no damage		N/A
24.16	Force necessary for covers or cover-plates to come off or not to come off (accessibility to insulating parts, earthed metal parts, live parts of SELV ≤ 25 V a.c. or metal parts separated from live parts by creepage distances twice those according to table 23)		
24.14.1	Verification of the non-removal of covers or cover-plates		
	Force 10 N applied for 1 min in direction perpendicular to the mounting surface: covers or cover-plates did not come off		N/A
	Test repeated on new specimens with a sheet of hard material, 1 mm ± 0,1 mm thick, fitted around the supporting frame (fig. 31): covers or cover-plates did not come off		N/A
	After the test: no damage		N/A
24.14.2	Verification of the removal of covers or cover-plates		
	Force not exceeding 120 N applied 10 times in direction perpendicular to the mounting / supporting surface: covers or cover-plates came off		N/A
	Test repeated on new specimens with a sheet of hard material, 1 mm ± 0,1 mm thick, fitted around the supporting frame (fig. 31): covers or cover-plates came off		N/A
	After the test: no damage		N/A
24.17	Test with gauge of figure 7 applied according to figure 9 for verification of the outline of covers or cover-plates: distances between face C of gauge and outline of side under test, not decrease	complying / not complying	—
24.18	Test with gauge according to figure 5 applied as shown in figure 11 (1 N): gauge not enter more than 1mm	complying / not complying	—
24.19	Shroud of portable socket-outlets: compression test (20 ± 2) N at (25 ± 5) °C by means of the apparatus shown in figure 38		
	After 1 min and while the shrouds are still under pressure the dimensions did comply with the appropriate standard sheet		N/A
	Test repeated with the specimen rotated 90 °		N/A

IEC 60884-1			
Clause	Requirement + Test	Result - Remark	Verdict
25	RESISTANCE TO HEAT		
25.1	Specimens kept for 1 h in a heating cabinet at (100 ± 2) °C for 1 h		
	During the test: no change impairing their further use and sealing compound, if any, not flow		P
	After the test:		
	- no access to live parts with probe B of IEC 61032 applied with a force not exceeding 5 N		P
	- markings still legible		P
25.2	Parts of insulating material necessary to retain current-carrying parts and parts of the earthing circuit in position, as well as parts of the front surface zone, 2 mm wide, surrounding the phase and neutral pin entry holes: ball-pressure test at (125 ± 2) °C for 1 h	See appended table 25.2	P
25.3	Parts of insulating material not necessary to retain current-carrying parts and parts of the earthing circuit in position, even though in contact with them: ball-pressure test (1 h)	See appended table 25.3	P
25.4	Portable accessories: compression test (20 N) at (80 ± 2) °C for 1 h by means of the apparatus shown in figure 38		
	After the test: no damage		P
26	SCREWS, CURRENT-CARRYING PARTS AND CONNECTIONS		
26.1	Connections withstand mechanical stresses		P
	Thread-forming or thread-cutting screws used only if supplied together with the piece in which they are intended to be inserted		N/A
	Thread-cutting screws intended to be used during installation: captive		N/A
	Screws or nuts which transmit contact pressure made of metal and in engagement with a metal thread		N/A
	Threaded part torque test	See appended table 26.1	N/A
26.2	Screws in engagement with a thread of insulating material: correct introduction into the screw hole or nut ensured		P
26.3	Contact pressure: not transmitted through insulating material other than ceramic, pure mica or other material no less suitable unless there is sufficient resiliency in metallic parts		P
	Connections made by insulation piercing of tinsel cord reliable		N/A

IEC 60884-1			
Clause	Requirement + Test	Result - Remark	Verdict
26.4	Screws and rivets locked against loosening and/or turning		N/A
26.5	Current-carrying parts (including earthing terminals) have mechanical strength, electrical conductivity and resistance to corrosion adequate:		
	- copper;		N/A
	- alloy with at least 58 % copper for parts made from cold-rolled sheet or with at least 50 % copper for other parts;	> 58%	P
	- stainless steel with at least 13 % chromium and not more than 0,09 % carbon		N/A
	- steel with electroplated coating of zinc (ISO 2081): service condition ISO no. (1/2/3); IP (X0/X4/X5); thickness (µm)		N/A
	- steel with electroplated coating of nickel and chromium (ISO 1456): service condition ISO no. (2/3/4); IP (X0/X4/X5); thickness (µm)		N/A
	- steel with electroplated coating of tin (ISO 2093): service condition ISO no. (2/3/4); IP (X0/X4/X5); thickness (µm)		N/A
	Current-carrying parts subjected to mechanical wear: not of steel with electroplated coating		P
	Metals having a great difference of electrochemical potential: not used in contact with each other		P
26.6	Contacts subjected to a sliding action are of metal resistant to corrosion		P
26.7	Thread-forming screws and thread-cutting screws are not used for the connection of current-carrying parts		N/A
	Thread-forming screws and thread-cutting screws used to provide earthing connection: it is not necessary to disturb the connection and at least two screws are used for each connection		N/A
27	CREEPAGE DISTANCES, CLEARANCES AND DISTANCES THROUGH SEALING COMPOUND		
27.1	Creepage distances, clearances and distances through sealing compound are not less than the values shown in table 23	See appended table 27.1	P
27.2	Insulating sealing compound does not protrude above the edge of the cavity in which it is contained		N/A
27.3	Surface-type socket-outlets do not have bare current-carrying strips at the back		N/A

IEC 60884-1			
Clause	Requirement + Test	Result - Remark	Verdict
28	RESISTANCE OF INSULATING MATERIAL TO ABNORMAL HEAT, TO FIRE AND TO TRACKING		
28.1	Resistance to abnormal heat and to fire		
28.1.1	Glow-wire test according to IEC 60695-2-10 and IEC 60695-2-11	See appended table 28.1.1	P
28.1.2	Plugs with pins provided with insulating sleeves:		
	Test temperature maintained for 3 h by means of the apparatus shown in figure 40 at (120 ± 5) °C / (180 ± 5) °C		—
	Impact test according to sub-clause 30.4 (mass 100 g, height 100 mm, 4 impacts): no cracks of the insulating sleeves		N/A
28.2	Resistance to tracking		
	Parts of insulating material retaining live parts in position of accessories having IP>X0: of material resistant to tracking		N/A
	Tracking test at 175 V with solution A of IEC 60112	See appended table 28.2	N/A
29	RESISTANCE TO RUSTING		N/A
30	ADDITIONAL TESTS ON PINS PROVIDED WITH INSULATING SLEEVES		N/A

IEC 60884-1			
Clause	Requirement + Test	Result - Remark	Verdict

12.2.5	TABLE: test with apparatus shown in figure 11 (screw-type terminals)		N/A
--------	--	--	-----

12.2.6	TABLE: pull test (screw-type terminals)		N/A
--------	---	--	-----

12.2.7	TABLE: tightening test (screw-type terminals)		N/A
--------	---	--	-----

12.3.10	TABLE: mechanical strength test (screwless-type terminals)		N/A
---------	--	--	-----

12.3.11	TABLE: electrical and thermal strength test (screwless-type terminals)		N/A
---------	--	--	-----

12.3.12	TABLE: deflection test (principle of test apparatus shown in figure 12a)		N/A
---------	--	--	-----

14.22	TABLE: Components		P
-------	-------------------	--	---

Object / part No.	Manufacturer/ trademark	Type / model	Technical data	Standard	Mark(s) of conformity ¹⁾
plug	Suzhou Bortly Hardware Illumination Electric Appliance Co. Ltd	-	250 V~; 16 A	IEC 60884-1 NEN 1020	tested with product
shutter	Suzhou East Haichang Molded Products Co.,Ltd	-	PC	IEC 60884-1 NEN 1020	tested with product
material supporting contacts	Suzhou East Haichang Molded Products Co.,Ltd	-	PBT	IEC 60884-1 NEN 1020	tested with product
housing	Suzhou East Haichang Molded Products Co.,Ltd	-	PC	IEC 60884-1 NEN 1020	tested with product
USB charger	Suzhou Bortly Hardware Illumination Electric Appliance Co. Ltd	USB13EU2A	Input: 250 V~ Output: 5 Vdc; 2,1 A	IEC/EN 60950-1	test with product (DEKRA test report 3137082.50)

Supplementary information:

¹⁾ Provided evidence ensures the agreed level of compliance. See OD-CB2039.

17.1	TABLE: insulation resistance		P
Item per 17.1	test voltage applied between:	measured (MΩ)	required (MΩ)
a)	all poles connected together and the body	5000	5

IEC 60884-1			
Clause	Requirement + Test	Result - Remark	Verdict
b)	each pole in turn and all others, these being connected to the body	5000	5
supplementary information:			

17.2	TABLE: electric strength			P
	rated voltage (V)	250		—
item per 17.1	test voltage applied between:	test voltage (V)	flashover / breakdown (Yes/No)	
a)	all poles connected together and the body	2000	No	
b)	each pole in turn and all others, these being connected to the body	2000	No	
supplementary information:				

19.1	TABLE: temperature rise test for socket-outlets and plugs							P
	rated current of accessory (A)	16						—
	type of accessory (non-rewirable / rewirable)	-						—
	nominal cross-sectional area per table 15 (mm ²) ..	-						—
	type of conductors (rigid solid / rigid stranded / flexible).....	-						—
	nominal diameter of thread (mm); torque 2/3 of that specified in 12.2.8 (Nm	-						—
specimen	type of flexible cable ⁽¹⁾	number of conductors and nominal cross-sectional area (mm ²) ⁽¹⁾	test circuit (L-L/L-N/L-E)	test current (table 20) for 1 h (A)	measured ΔT (K)	allowed ΔT (K)	ΔT of external parts of insulating material (25.3)(K)	
1,2,3	-	-	L-N	20	< 34	45	< 34	
1,2,3	-	-	L-E	20	< 27	45	< 27	
16,17,18	-	-	L-N	20	< 32	45	< 32	
16,17,18	-	-	L-E	20	< 21	45	< 21	
supplementary information:								
⁽¹⁾ Non-rewirable accessories								

19.2	TABLE: temperature rise test for fixed socket-outlets of a socket-outlet and fused plug system		N/A

19.3	TABLE: temperature rise test for plugs and portable socket-outlets with incorporated components		P
	rated current of accessory (A)	16	—

IEC 60884-1								
Clause	Requirement + Test				Result - Remark			Verdict
	type of accessory (non-rewirable / rewirable) .. :				-			—
	nominal cross-sectional area per table 15 (mm²) :				-			—
	type of conductors (rigid solid / rigid stranded / flexible)..... :				-			—
	nominal diameter of thread (mm); torque 2/3 of that specified in 12.2.8 (Nm..... :				-			—
Test for Portable socket-outlets and rewirable plugs with incorporated components								
specimen	type of flexible cable ⁽¹⁾	number of conductors and nominal cross-sectional area (mm ²) ⁽¹⁾	test circuit (L-L/L-N/L-E)	Test current (table 20), Clause 19 for 1 h (components short circuited) (A)	Test current is rated current of the portable accessory or the rated current of the component (s), whichever is the lower (A)	measured ΔT (K)	allowed ΔT (K)	ΔT of external parts (25.3)(K) ⁽²⁾
1,2,3	-	-	L-N	20	-	< 34	45	< 34
1,2,3	-	-	L-E	20	-	< 27	45	< 27
1,2,3	-	-	L-N	-	16	< 34	45	< 34
1,2,3	-	-	L-E	-	16	< 27	45	< 27
16,17,18	-	-	L-N	20	-	< 32	45	< 32
16,17,18	-	-	L-E	20	-	< 21	45	< 21
16,17,18	-	-	L-N	-	16	< 32	45	< 32
16,17,18	-	-	L-E	-	16	< 21	45	< 21
supplementary information:								
⁽¹⁾ Non-rewirable accessories ; ⁽²⁾ Metal parts 30 K ; non-metallic parts 40 K								
Test for non-rewirable plugs with incorporated components								N/A
specimen	type of flexible cable (1)	number of conductors and nominal cross-sectional area (mm ²) (1)	test circuit (L-L/L-N/L-E)	Test current is equal to the test current for the combination of the plug and the cable as indicated in Table 20, for Clause 19. (components short circuited) (A)	Test current is equal to the test current for the combination of the plug and the cable as indicated in Table 20, for Clause 21 or the rated current of the component (s), whichever is the lower (A)	measured ΔT (K)	allowed ΔT (K)	ΔT of external parts (25.3)(K) ⁽²⁾
-	-	-	-	-	-	-	-	-

IEC 60884-1			
Clause	Requirement + Test	Result - Remark	Verdict

supplementary information:

(¹) Non-rewirable accessories; (²) Metal parts 30 K ; non-metallic parts 40 K

20	TABLE: breaking capacity								P
	rating of accessory (A/V)			16 / 250					—
	type of accessory (non-rewirable / rewirable) ..			Non-rewirable					—
	type of flexible cable (non-rewirable accessories)			-					—
	number of conductors and nominal cross-sectional area (mm ²) (non-rewirable accessories)			-					—
	nominal cross-sectional area per table 15 (mm ²)			-					—
	type of conductors (rigid solid / rigid stranded / flexible).....			-					—
	nominal diameter of thread (mm); torque 2/3 of that specified in 12.2.8 (Nm).....			-					—
	rate of operation (strokes per minute)			30					—
specimen	test plug (for each type and current rating of socket-outlet)		test voltage (1,1 Vn) (V)	test current (1,25 In) cos φ 0,6 (A)	number of strokes (plugs only)	number of strokes, with shutters – with current (¹)	number of strokes, without shutters – with current (²)	remarks	
	pin dimensions (mm)	pin spacing (mm)							
1,2,3	4,86	19,0	275	20	-	100	-	-	P

21	TABLE: normal operation								P
	rating of accessory (A/V)			16 / 250					—
	type of accessory (non-rewirable / rewirable) ..			Non-rewirable					—
	type of flexible cable (non-rewirable accessories)			-					—
	number of conductors and nominal cross-sectional area (mm ²) (non-rewirable accessories)			-					—
	nominal cross-sectional area per table 15 (mm ²)			-					—
	type of conductors (rigid solid / rigid stranded / flexible).....			-					—

IEC 60884-1										
Clause	Requirement + Test					Result - Remark			Verdict	
	nominal diameter of thread (mm); torque 2/3 of that specified in 12.2.8 (Nm)..... :					-			—	
	rate of operation (strokes per minute)					30			—	
specimen	test plug (for each type and current rating of socket-outlet)		test voltage (Vn) (V)	test current (table 20), $\cos \varphi 0,8$ (A)	number of strokes (plugs only)	number of strokes, with shutters – with current ⁽¹⁾	number of strokes, without shutters – with current ⁽²⁾	number of strokes, with shutters – without current ⁽³⁾		
	pin dimensions (mm)	pin spacing (mm)								
1,2,3	4,86	19,0	250	16	-	10 000	-	-	P	
1,2,3	4,86	-	-	-	10 000	-	-	-	P	
TABLE: test for shuttered socket-outlets										
specimen	Gauge of figure 9, applied with a force of 20 N, for approximately 5 s, successively in three directions				Steel gauge of figure 10, applied with a force of 1 N for approximately 5 s, in three directions					
1,2,3	no access to live parts				no access to live parts				P	
19	TABLE: temperature rise test									
specimen	test circuit (L-L/L-N/L-E)		test current (table 20 for clause 21) for 1 h (A)		measured dT (K)		allowed dT (K)			
1,2,3	L-N		16		40		45		P	
1,2,3	L-E		16		30		45		P	
17.2	TABLE: electric strength									
specimen	item per 17.1	test voltage applied between:			test voltage (V)		flashover / breakdown (Yes/No)			
1,2,3	a)	all poles connected together and the body			1500		No			
1,2,3	b)	each pole in turn and all others			1500		No			
supplementary information:										
⁽¹⁾ starting point 1 or 3 of Figure 43										
⁽²⁾ starting point 2 of Figure 43										
⁽³⁾ starting point 1 or 2 of Figure 43										
22	TABLE: force necessary to withdraw the plug									P
	Rated current (A)					16			—	

IEC 60884-1					
Clause	Requirement + Test			Result - Remark	Verdict
	Number of poles : 3				—
22.1	Verification of the maximum withdrawal force				
specimen	socket-outlets (multi-pin gauge)		plugs with resilient earthing contact assemblies (single-pin gauge)		
	maximum withdrawal force (N)	the test plug did not remain in the socket-outlet (Y/N)	maximum withdrawal force (N)	the test pin gauge did not remain in the contact assembly	
1,2,3	54	Y	-	-	P
1,2,3	-	-	25	-	P
22.2	Verification of the minimum withdrawal force				
specimen	socket-outlets (single-pin gauge)		plugs with resilient earthing contact assemblies (single-pin gauge)		
	minimum withdrawal force (N)	the test pin gauge did not fall from each individual contact-assembly within 30 s (Y/N)	minimum withdrawal force (N)	the test pin gauge did not fall from each individual earthing contact-assembly within 30 s (Y/N)	
1,2,3	2	Y	-	-	P
1,2,3	-	-	2	-	P
supplementary information:					
23.2	TABLE: pull and torque test				N/A
23.4	TABLE: flexing test				N/A
24.1	TABLE: impact test				N/A
25.2	TABLE: ball pressure test of insulating materials				P
	allowed impression diameter (mm) : ≤ 2 mm				—
part under test			test temperature (°C)	impression diameter (mm)	
material supporting contacts			125	0,8	
shutter			125	1,0	
PCB			125	0,7	
supplementary information:					
25.3	TABLE: ball pressure test of insulating materials				P

IEC 60884-1			
Clause	Requirement + Test	Result - Remark	Verdict

	allowed impression diameter (mm)	≤ 2 mm	—
part under test		test temperature (°C) ⁽¹⁾	impression diameter (mm)
enclosure		70	0,7
supplementary information:			
⁽¹⁾ (70 ± 2) °C / (40 ± 2) °C + highest temperature rise determined during the test of clause 19			

26.1	TABLE: threaded part torque test	N/A
-------------	---	------------

27.1	TABLE: creepage distances, clearances and distances through sealing compound							P
	rated voltage (V)	250						—
item per table 23	creepage distance dcr, clearance cl and distance through sealing compound dtsc at/of:	require d cl (mm)	cl (mm)	require d dcr (mm)	dcr (mm)	require d dtsc (mm)	dtsc (mm)	
1 and 6	Live parts of different polarity	≥ 3	> 5	≥ 3	> 5	-	-	
2 and 7	Live parts and accessible surface of insulating material	≥ 3	> 5	≥ 3	> 5	-	-	
2 and 7	Live parts and earthed metal parts including parts of earthing circuit	≥ 3	> 5	≥ 3	> 5	-	-	
2 and 7	Live parts and external assembly screws, other than screws which are on the engagement face of plug and are isolated from the earthing circuit	≥ 3	> 5	≥ 3	> 5	-	-	
supplementary information:								

28.1.1	TABLE: glow-wire test					P
part under test	material designation	test temperature (°C)	visible flame and sustained glowing (Y/N)	flame and glowing extinction time	ignition of the tissue paper (Y/N)	
material supporting contacts	PBT	750	N	0	N	
shutters	PC	750	N	0	N	
enclosure	PC	650	N	0	N	
PCB	-	750	N	0	N	
supplementary information:						

28.2	TABLE: resistance to tracking	N/A
-------------	--------------------------------------	------------

NEN 1020:1987+A2:2004			
Clause	Requirement + Test	Result - Remark	Verdict
7	Classification		
7.2.4	Fixed socket-outlets shall be of design A		N/A
7.3	Plugs for equipment of Class 0 are allowed		N/A
8	MARKING		
	Plugs and /or socket-outlets that form an integral part of an equipment need not to be marked, provided that the rating, manufacturer's name and type reference are marked on the equipment		N/A
	non-rewirable multiple portable socket-outlets provided with a cable of a cross-sectional area of 1,0 mm ² shall be additional marked with "MAX. 2500 W"		N/A
9	CHECKING OF DIMENSIONS		
9.1	Accessories shall comply with the appropriate standard sheets specified in Annex A		P
	Dimensional compliance is checked by means of gauges specified in Annex A		P
	Gauge C1 (Figure 1)		P
	Gauge C1A (Figure 105)		N/A
	Gauge C2 (Figure 2)		P
	Gauge C3 (Figure 3)		P
	Gauge C3A (Figure 106)		N/A
	Gauge C4 (Figure 4)		P
	Gauge C6 (Figure 6)		N/A
	Gauge C7 (Figure 7)		P
	Gauge C8 (Figure 8)		N/A
	Gauge C9 (Figure 9)		P
	Gauge C10 (Figure 10)		P
	Gauge C11 (Figure 11)		P
	Gauge C12 (Figure 12)		N/A
	Gauge C13 (Figure 13)		N/A
	Gauge C15 (Figure 15)		N/A
	Gauge C16 (Figure 16)		P
	Gauge C18 (Figure 18)		P
	Gauge C19 (Figure 19)		P
	Gauge C19a (Figure 19a)		P

NEN 1020:1987+A2:2004			
Clause	Requirement + Test	Result - Remark	Verdict
10	PROTECTION AGAINST ELECTRIC SHOCK		
10.3	It shall not be possible to make contact between a pin of a plug and a live socket-contact of a socket-outlet while any other pin is accessible.		P
	Compliance is checked by means of gauges		
	socket-outlet for 16 A without earthing contact by means of the gauge of Figure 18		N/A
	socket-outlet for 2,5 A for equipment of Class II by means of the gauge of Figure 104		N/A
	two-pole plugs by means of the gauge of Figure 19		P
	A shutter as the only means to prevent single-pole insertion is not allowed.		P
10.4	External parts of plugs and portable socket-outlets shall be of insulating material with the exception of:		
	- assembly screws and the like		P
	- current carrying and earthing contacts		P
	- earthing straps and metal rings around pins		N/A
10.6	Earthing contacts of a socket-outlet designed that they cannot be deformed by the insertion of a plug		P
	Test plug of Figure 19a is inserted into the socket-outlet with a force of 150 N for 1 min. axial to the earthing contact, if any, of a socket-outlet placed in such a position that the socket-contacts are in vertical position		
	After this test: socket-outlet still comply with the requirements of clause 9		P
13	CONSTRUCTION OF FIXED SOCKET-OUTLETS		N/A
14	CONSTRUCTION OF PLUGS AND PORTABLE SOCKET-OUTLETS		
14.6	Socket-contacts shall be resistant to corrosion and abrasion		P
	Compliance is check by the tests according to Clauses 20 and 21 and by inspection according to clause 26		P
14.21	Rewirable plugs for equipment of Class II are not allowed		N/A
	Cord-extension sets exclusively intended for connection to equipment of Class II are allowed		N/A
14.22	Switches incorporated in plugs shall comply with NEN-EN-IEC 61058		N/A

NEN 1020:1987+A2:2004			
Clause	Requirement + Test	Result - Remark	Verdict
	Fuses may not be incorporated in plugs		N/A
16	RESISTANCE TO AGEING, PROTECTION BY ENCLOSURES, AND RESISTANCE TO HUMIDITY		
	Plugs with IP44 construction shall have the maximum outline and length according to the relevant standard sheet		N/A
16.2.2	Socket-outlets are tested with and without a plug in engagement and with the lid, if any, closed		N/A
18	OPERATION OF EARTHING CONTACTS		
	Earthing contact shall provide adequate contact pressure and shall not deteriorate in normal use		P
	For socket-outlets compliance is checked by the tests of clause 18, 19, 20 and 21		P
	Force exerted measured in side earthing contacts not less than 5 N of each individual earthing contact	7,0 N	P
19	TEMPERATURE RISE		
	Multiple portable socket-outlets consisting 2,5 A socket-outlet portions only, are tested by means of a test plug provided with brass pins with a test current of:		N/A
	single type: 4 A		N/A
	twofold: 7,5 A		N/A
	threefold: 11 A		N/A
	fourfold: 14,5 A		N/A
	fivefold or more: 16 A		N/A
	Accessories incorporating dimmers, fuses, switches, energy regulators, etc. are not short-circuited for the purpose of this test		P
	The temperature rise of terminals and/or terminations may not exceed 45 K		P
21	NORMAL OPERATION		
	Force exerted measured in side earthing contacts not less than 60 % of the original value and not less than 5 N of each individual earthing contact	5,8 N	P
22	FORCE NECESSARY TO WITHDRAW THE PLUG		
22.1	two-pole 2,5 A accessory; multi-pin gauge 30 N		N/A

NEN 1020:1987+A2:2004			
Clause	Requirement + Test	Result - Remark	Verdict
	two-pole 16 A accessory; multi-pin gauge 48 N		N/A
	two-pole with PE 16 A accessory; multi-pin gauge 54 N		P
22.2	two-pole 2,5 A accessory; multi-pin gauge 5 N		N/A
	two-pole 16 A accessory; multi-pin gauge 8 N		N/A
	two-pole with PE 16 A accessory; multi-pin gauge 9 N		P

23	FLEXIBLE CABLES AND THEIR CONNECTION		
23.2	Rewirable accessories shall be tested with the following cables:		N/A
	6 A two-pole		-
	H03RT-H 2x0,75 mm ²		N/A
	H05RR-F 2x1,0 mm ²		N/A
	16 A two-pole		-
	H03RT-H 2x0,75 mm ²		N/A
	H05RR-F 2x1,5 mm ²		N/A
	16 A two-pole with PE		-
	H03RT-H 3x0,75 mm ²		N/A
	H05RR-F 3x1,5 mm ²		N/A

Annex standard sheet of the deviation of VII plug and III socket-outlet:

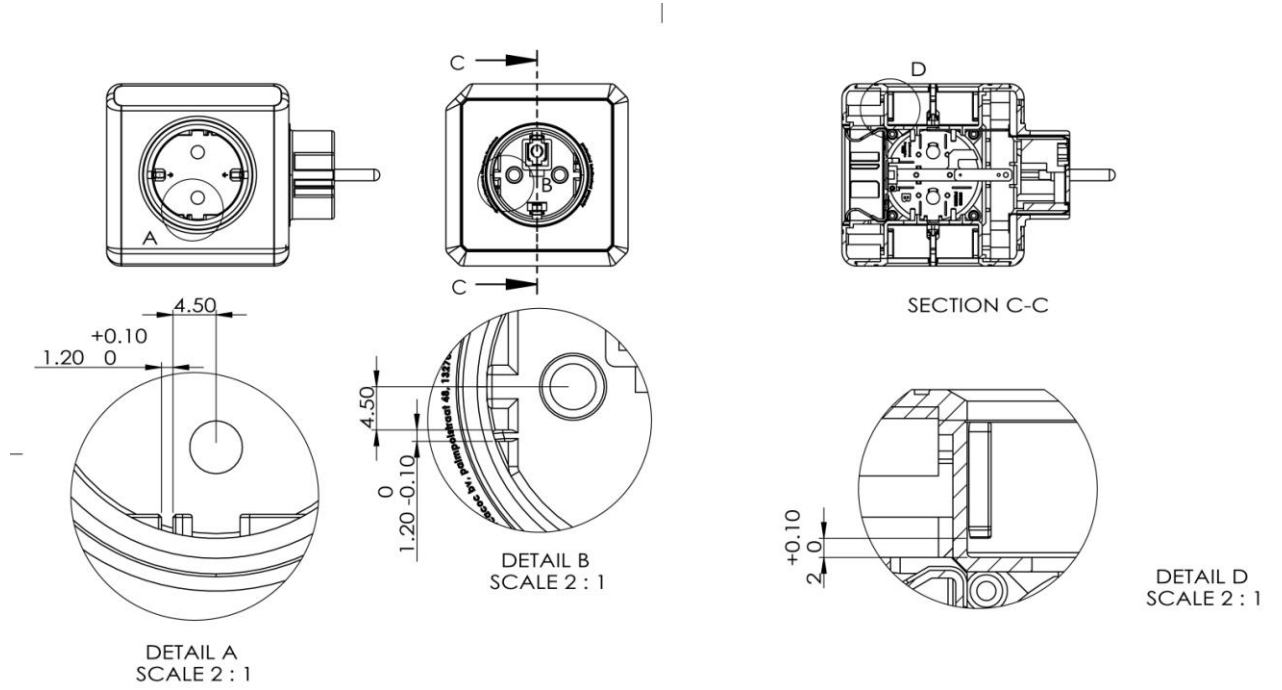

Annex datasheet III of CEE7 for socket-outlet portion

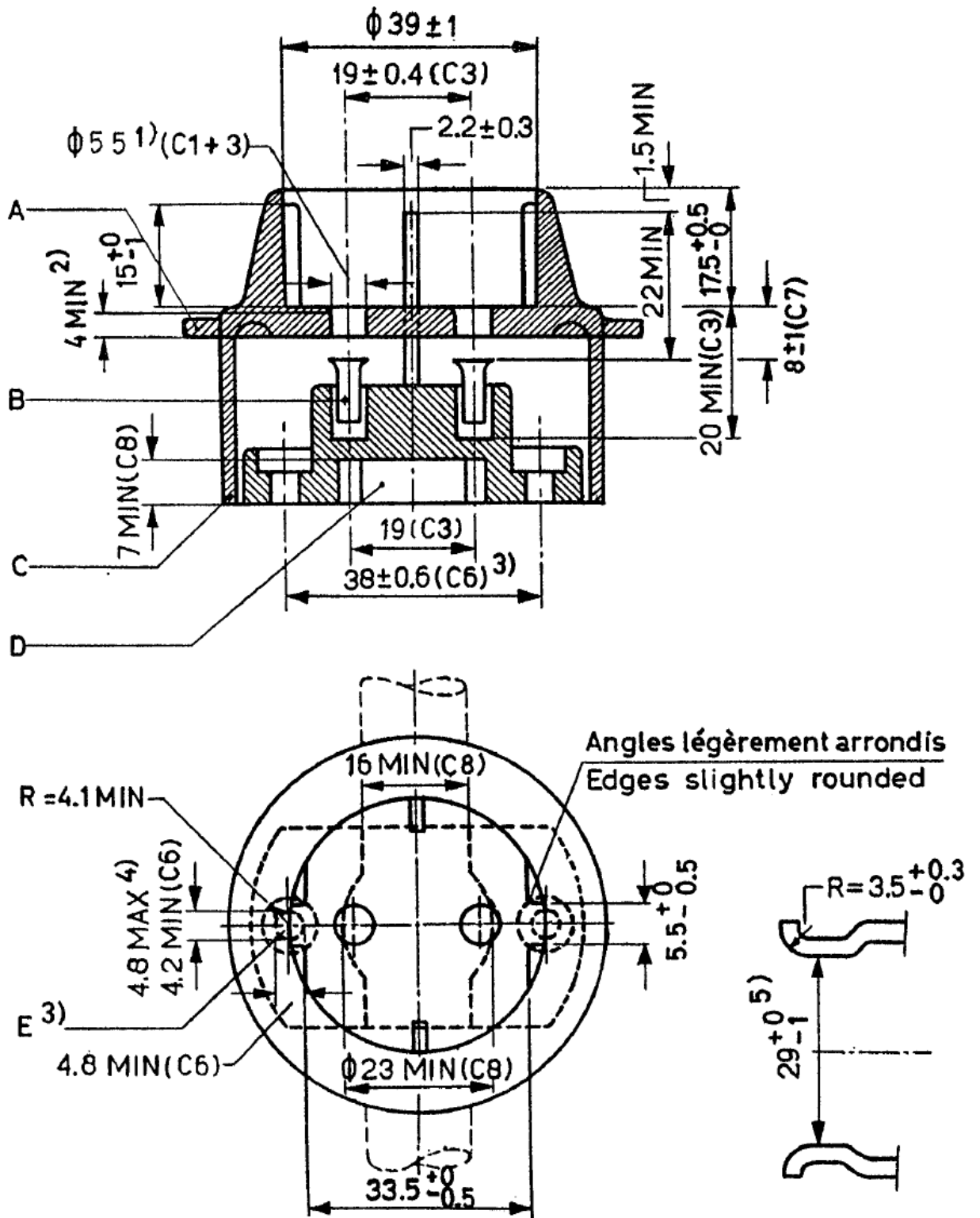

Annex datasheet VII of CEE 7 for plug portion

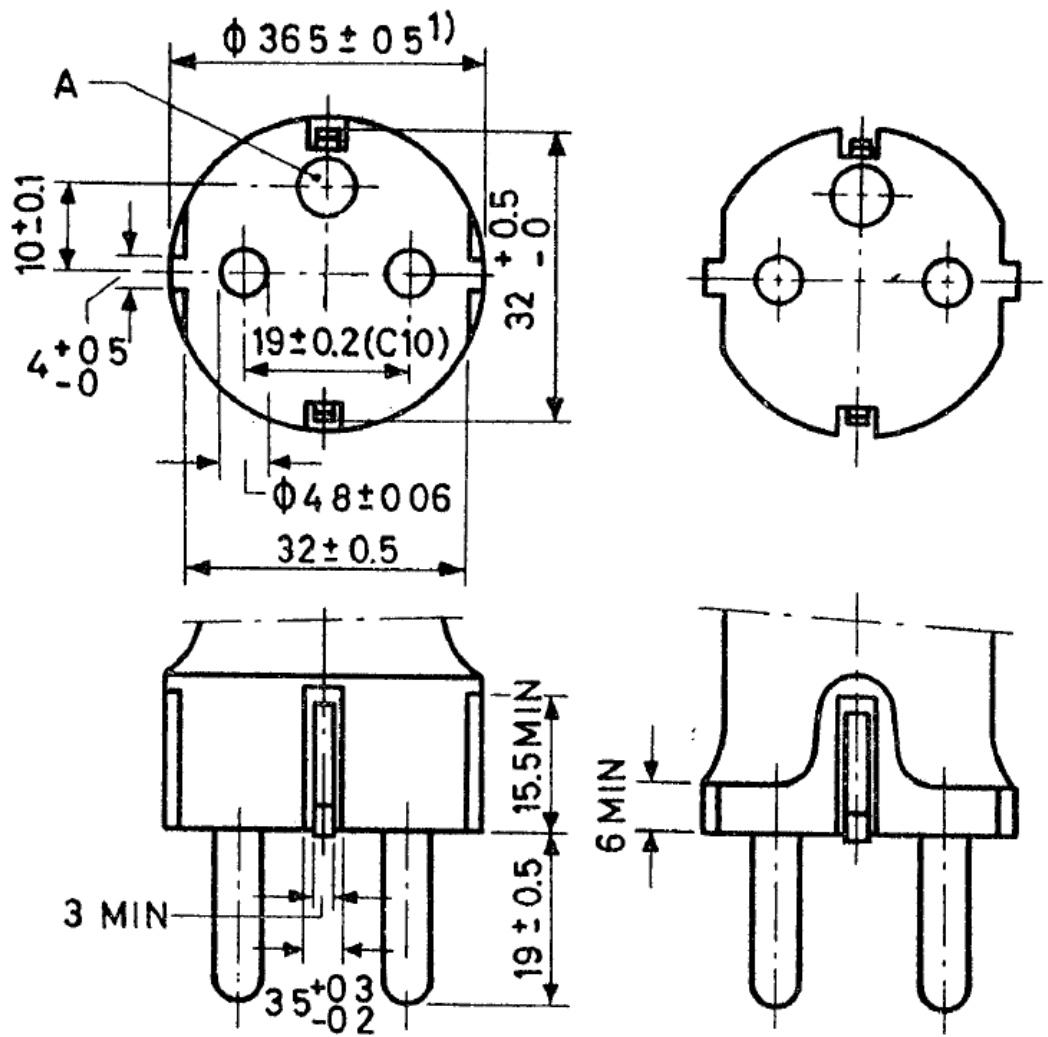

Annex pictures:

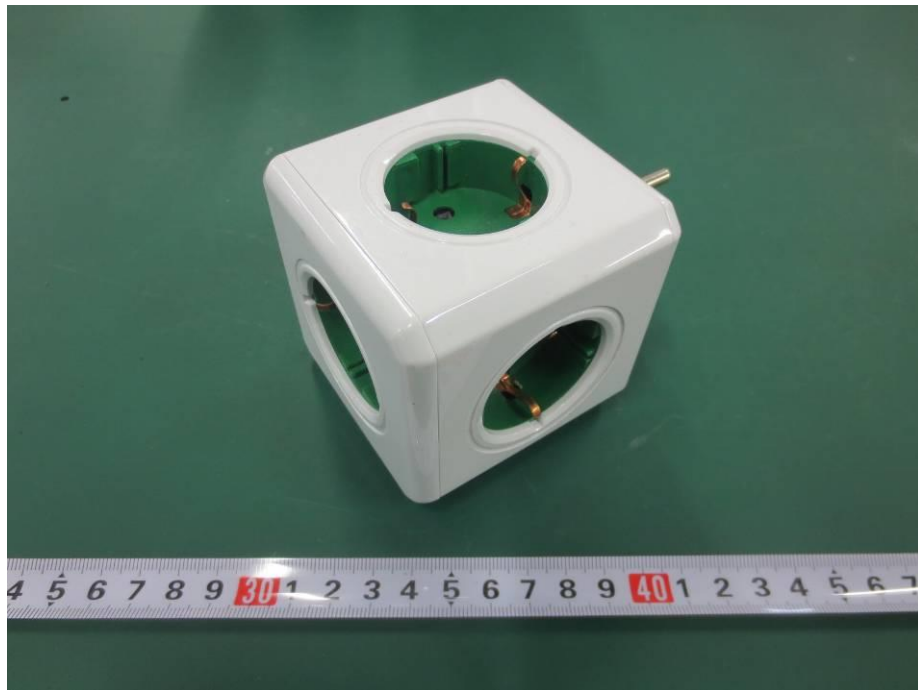

overview

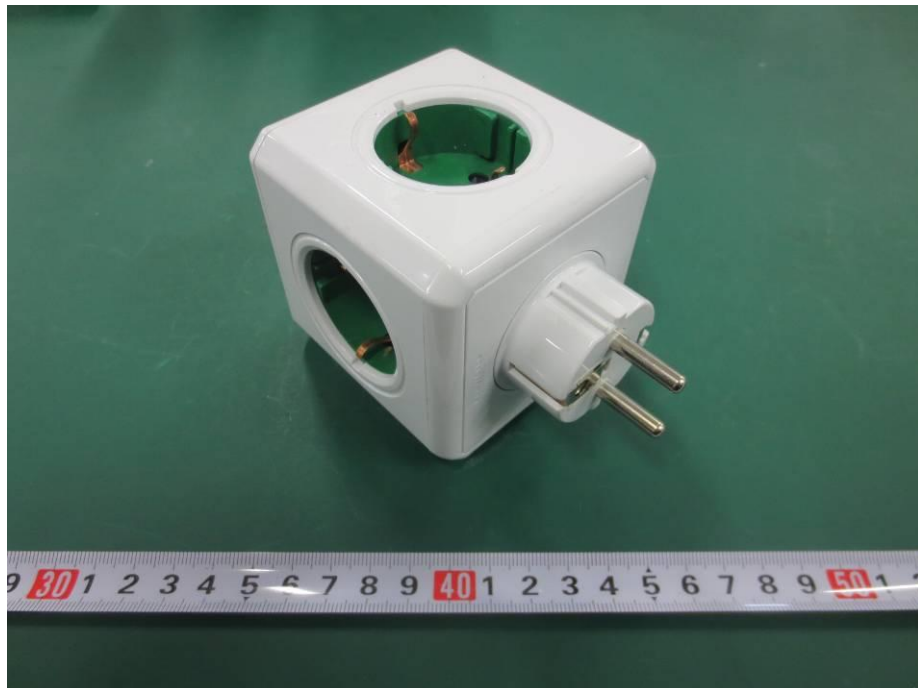

Annex pictures:

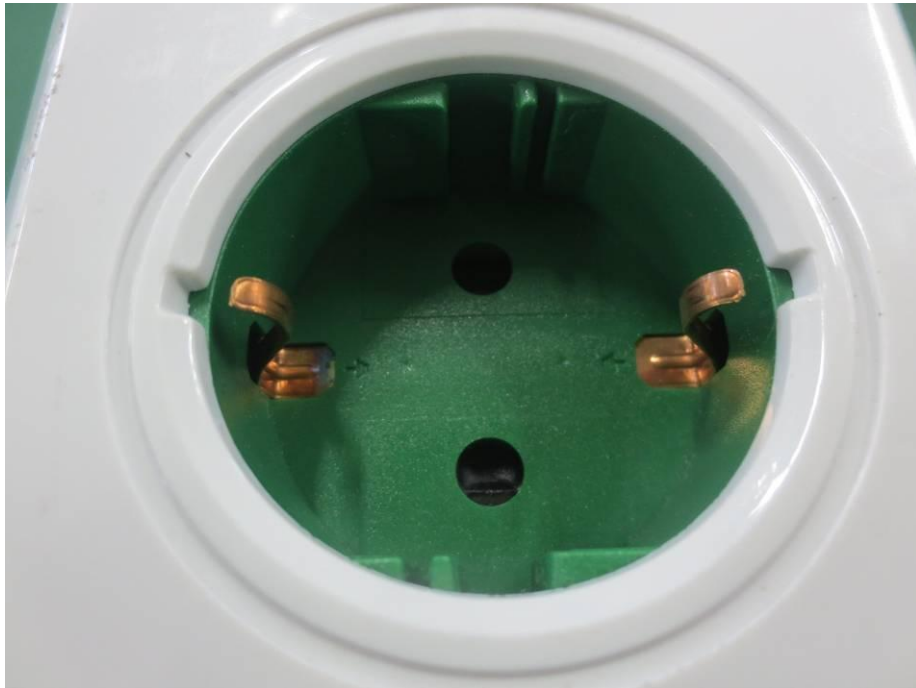

Annex pictures:

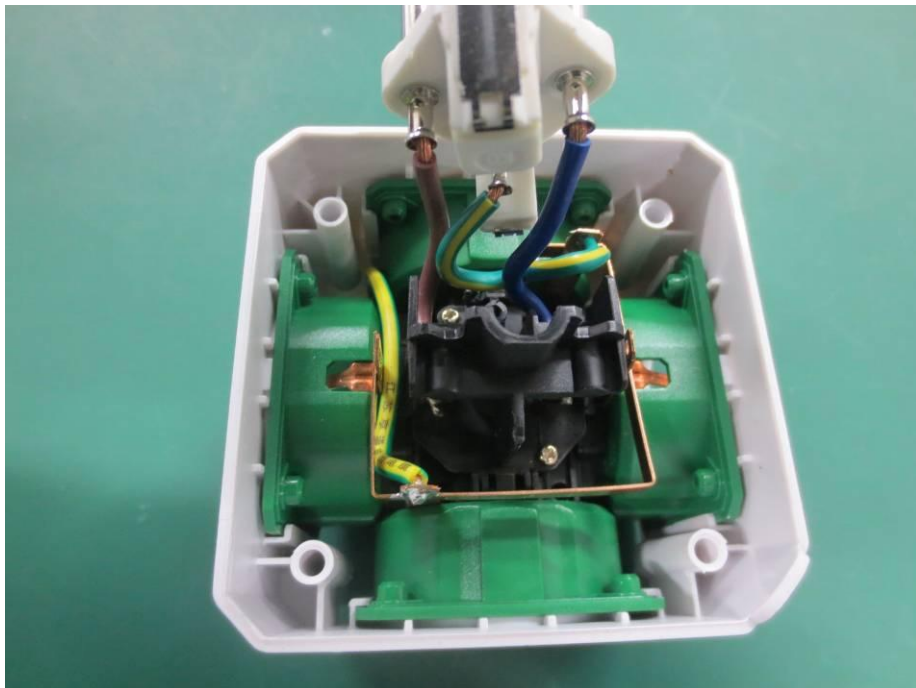

Annex pictures:

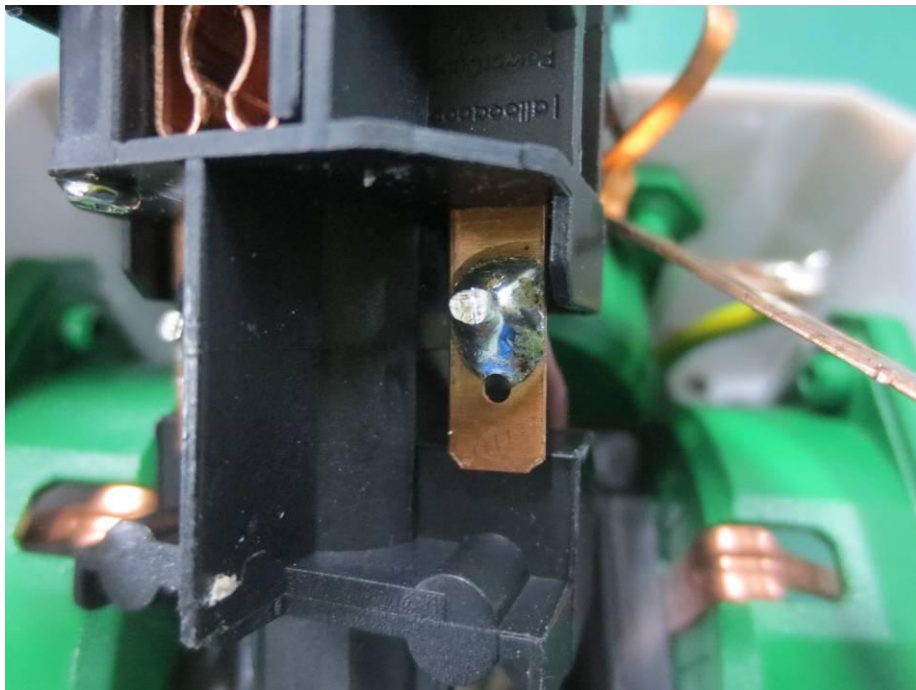
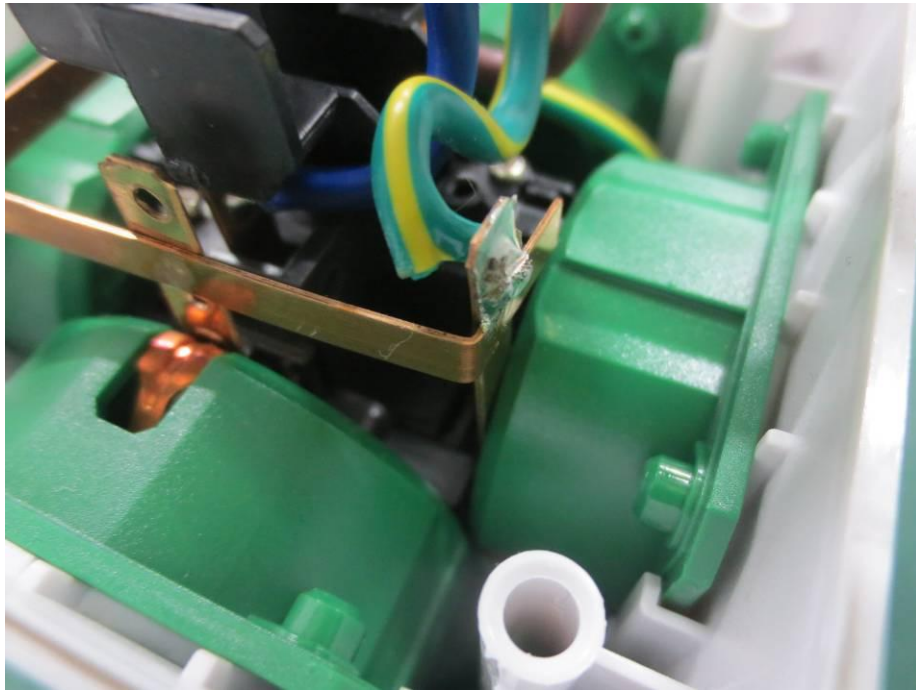

Annex pictures:

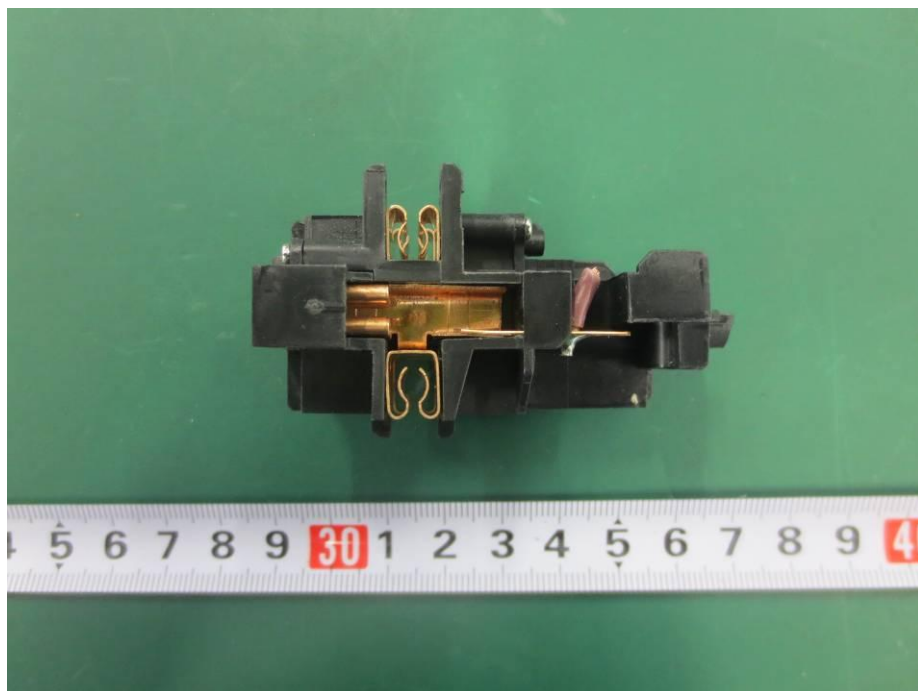
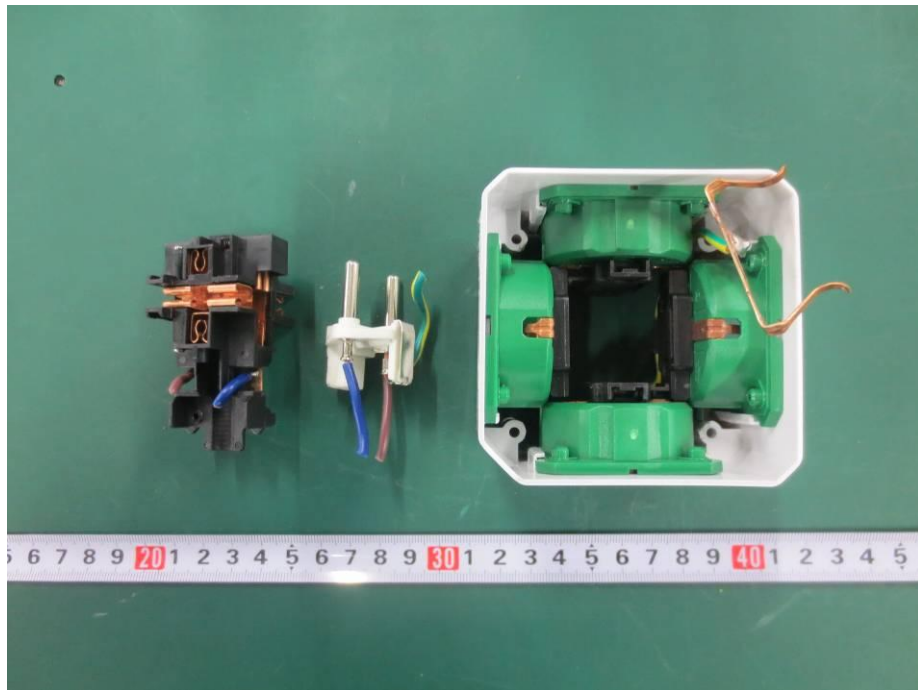

Annex pictures:

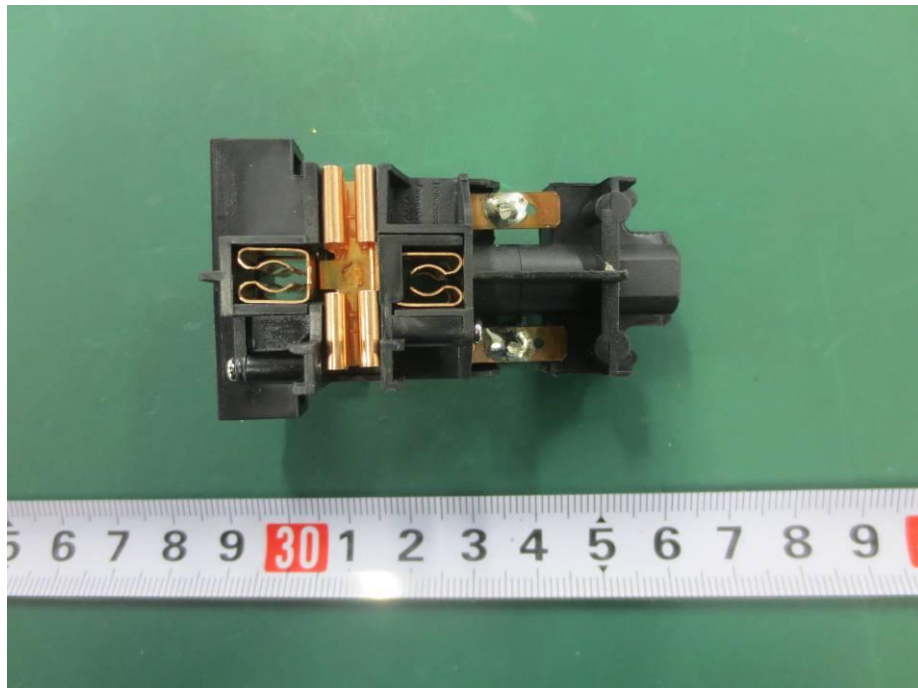
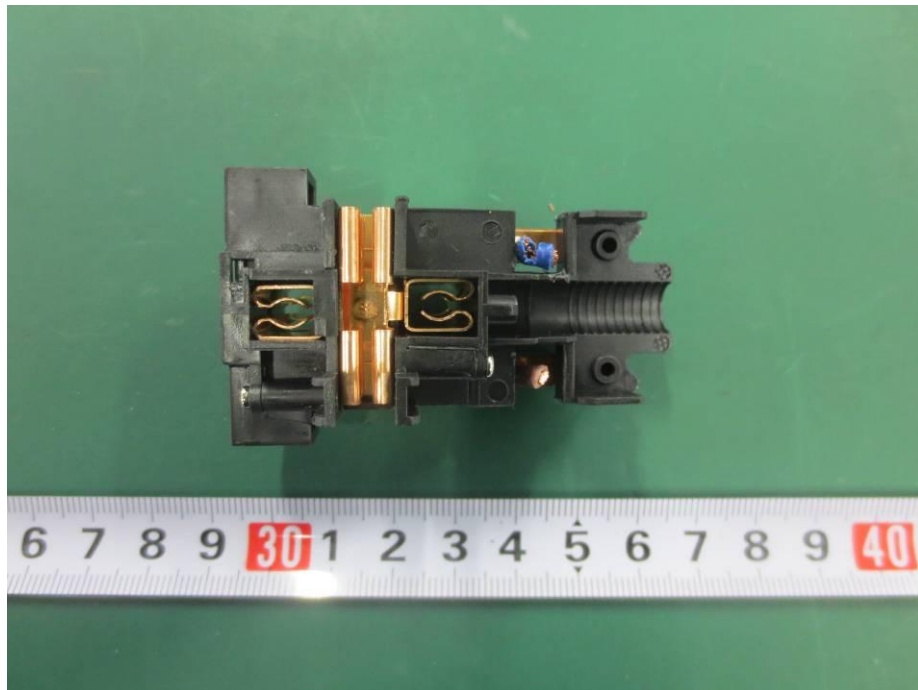

Annex pictures:

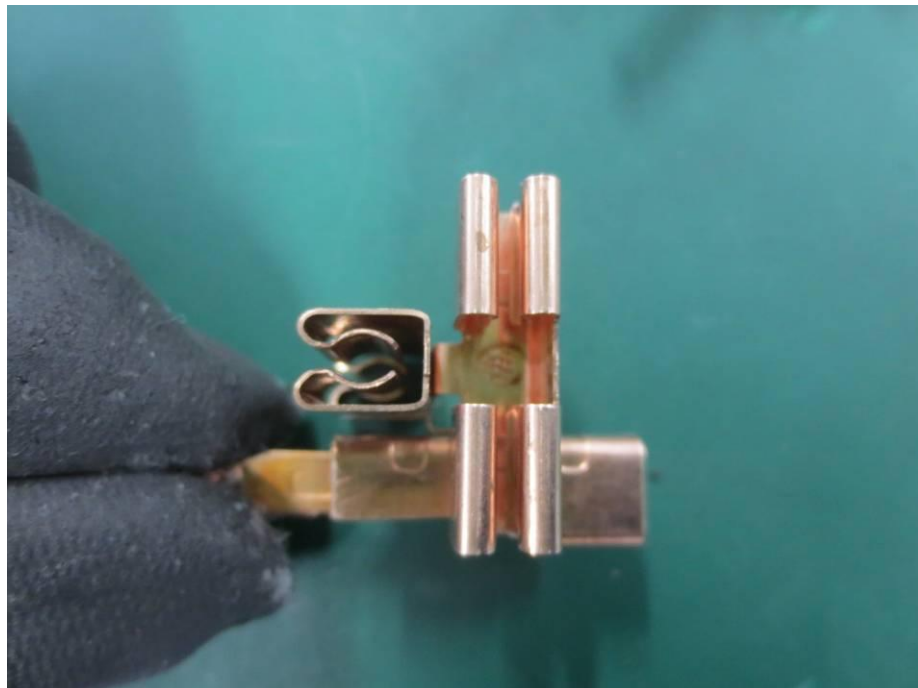

Annex pictures:

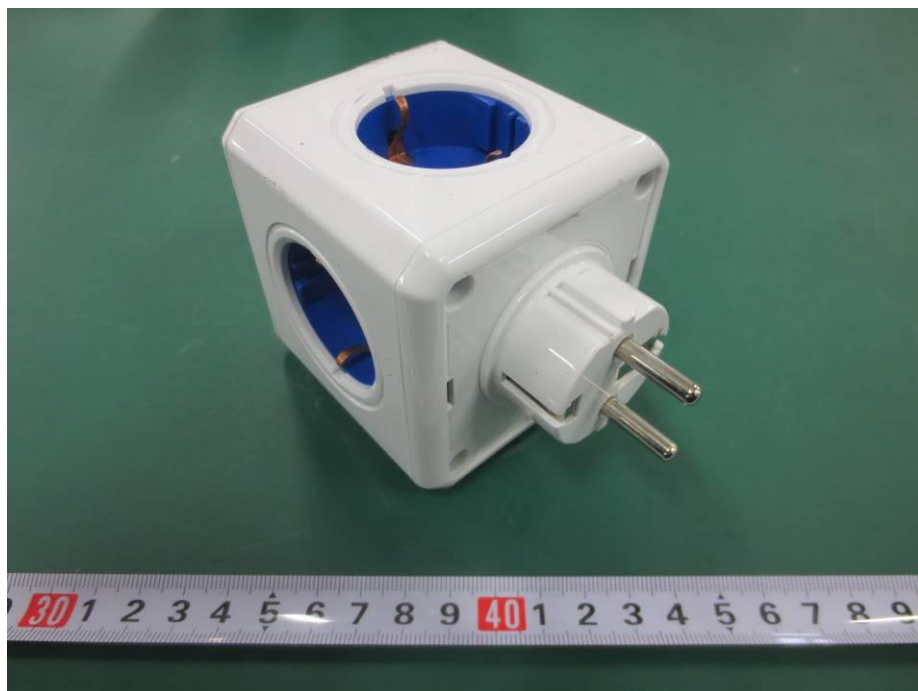
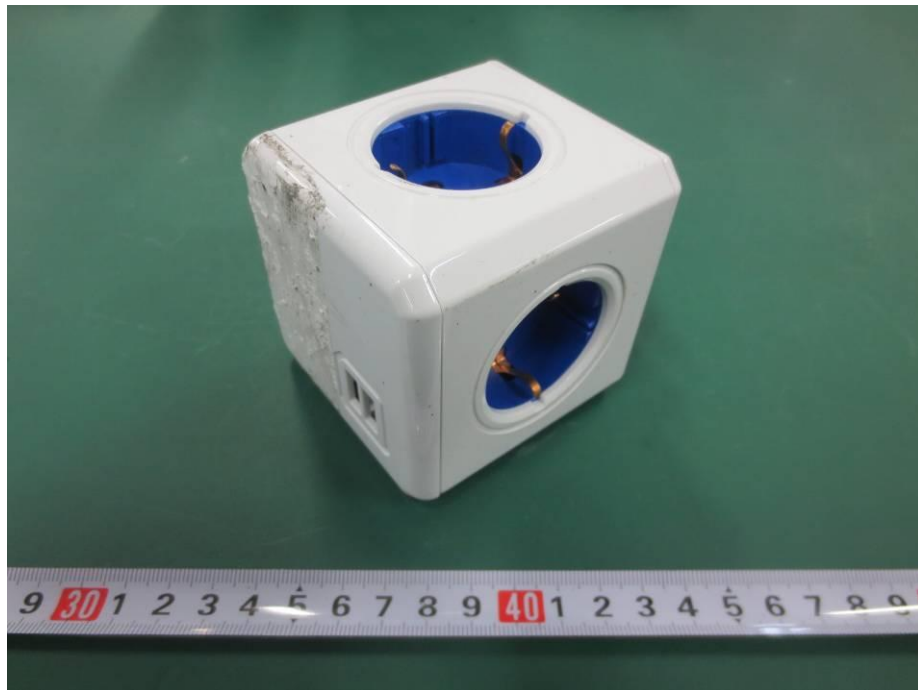

Annex pictures:

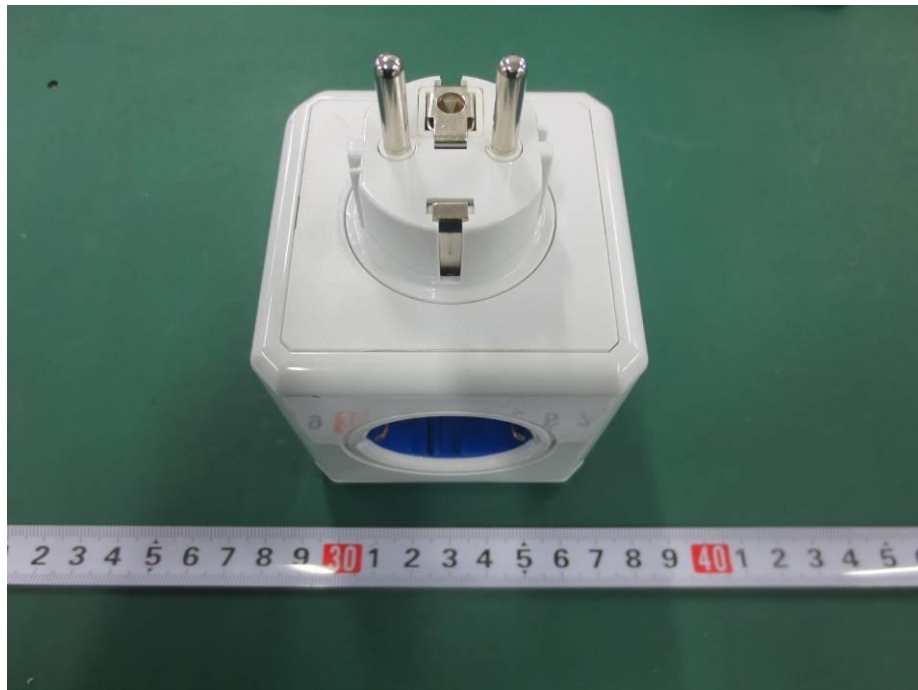

Annex pictures:

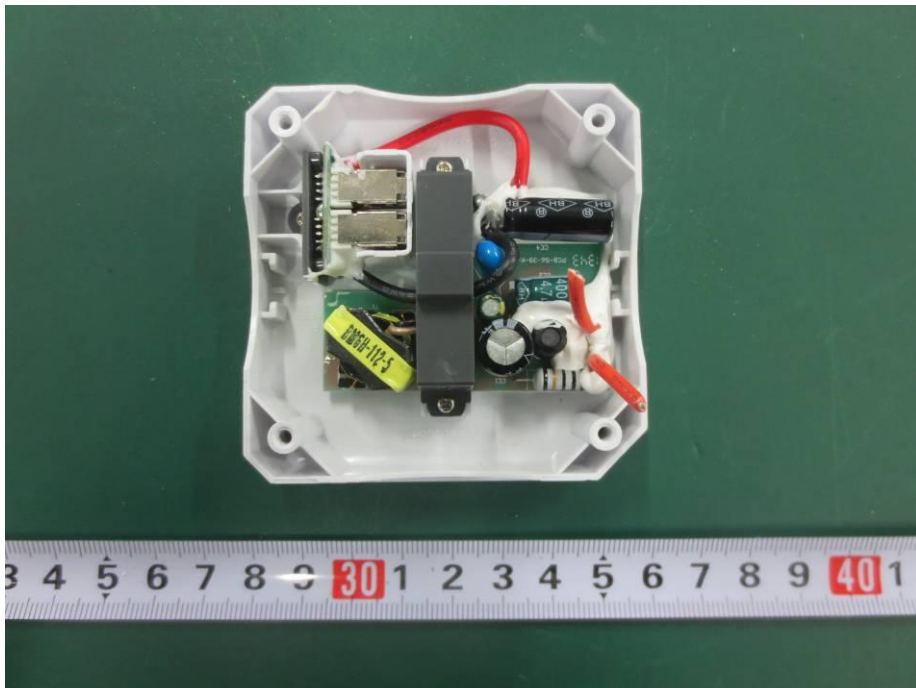
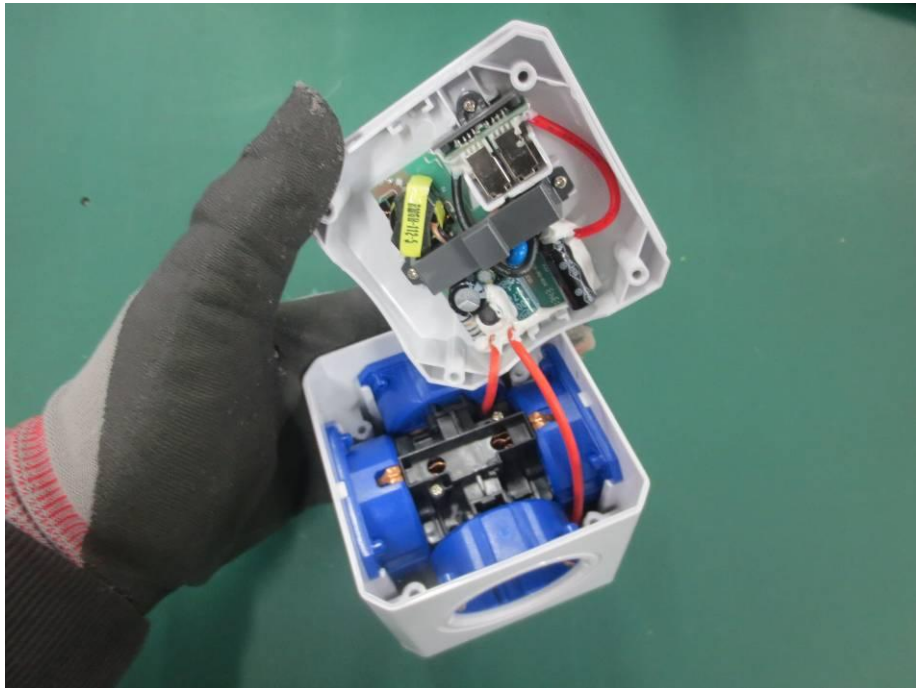

Annex pictures:

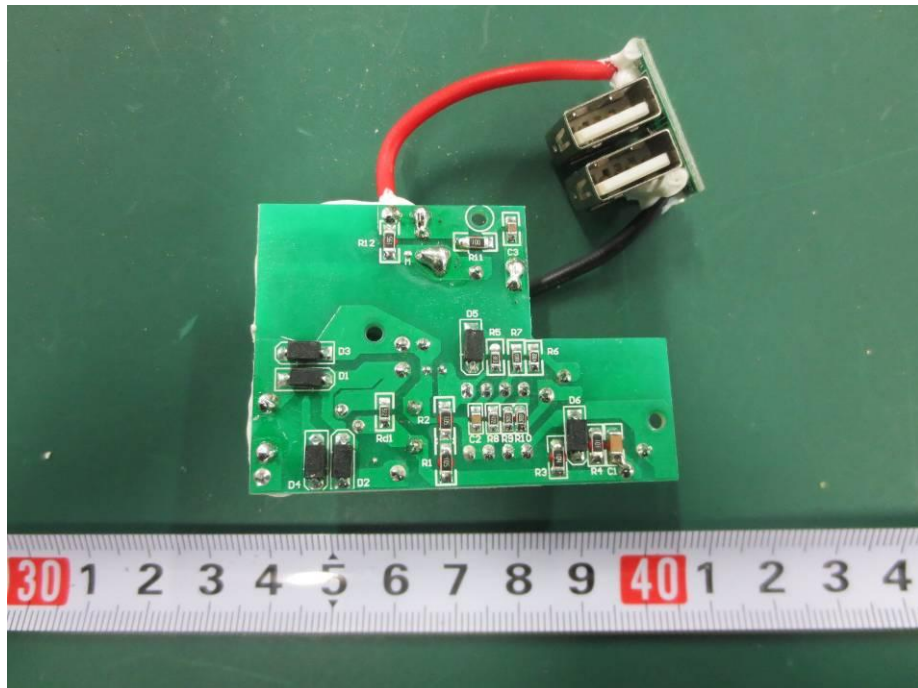
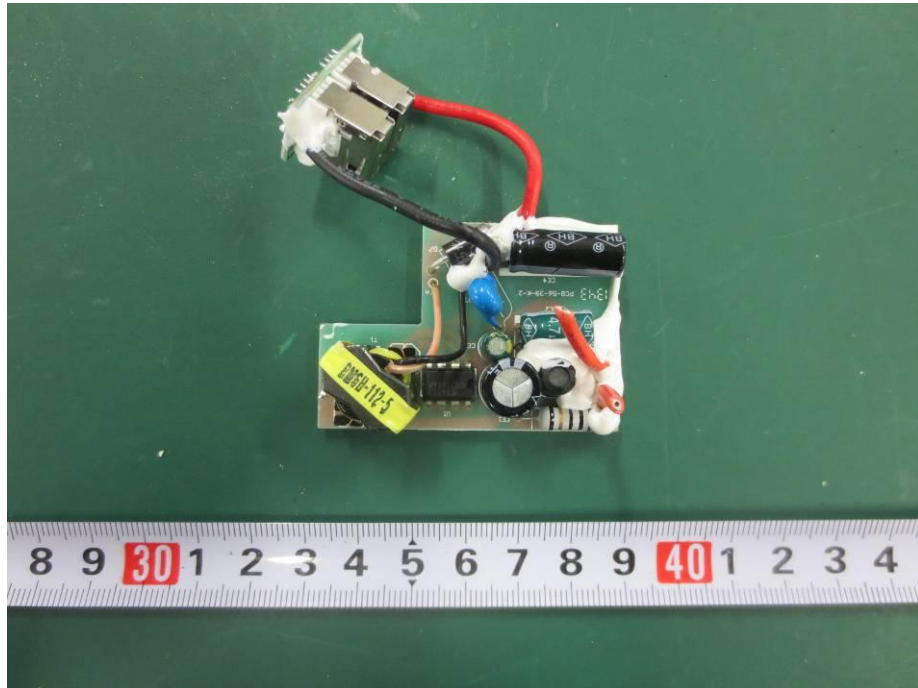

.....End of report.....